



LXF-L31-10D

XFP10Gb/s 1310nm Single-mode 10km DDM

PRODUCT FEATURES

- Supports 8.5Gb/s to 11.3Gb/s bit rates
- Uncooled 1310nm DFB laser transmitter and PIN/TIA receiver
- Up to 10km on 9/125umSMF
- Hot-pluggable XFP footprint
- Duplex LC connector
- Power dissipation < 1.5W
- No Reference Clock required
- RoHS-6 compliant and lead-free
- Support Digital Diagnostic Monitor interface
- Single +3.3V power supply
- Standard bail release mechanism
- Case operating temperature
Commercial: 0°C to +70°C

APPLICATIONS

- 10GBASE-SR/SW 10G Ethernet
- 1200-Mx-SN-I 10G Fiber Channel
- 800-SM-LC-L 8G Fiber Channel
- 10G CPRI

Compliance

- SFF-8472XFP MSA.
- Fiber Channel 1200-Mx-SN-I
- IEEE802.3ae

PRODUCT DESCRIPTION

LXF-L31-10D 10Gb/sXFP transceivers are compatible with the current XFP Multi-Sourcing Agreement (MSA) Specification. They comply with 10-Gigabit Ethernet 10GBASE-LR-LW per IEEE 802.3ae, 10G Fiber Channel 1200-Mx-SN-I and 8G Fiber Channel 800SM-LC-L. Digital diagnostics functions are available via a 2-wire serial interface, as specified in the XFP MSA. The optical transceiver is compliant per the RoHS Directive 2011-65-EU.

Ordering information

Package	Product part NO.	Data Rate(Gbps)	Media	Wavelength(nm)	Transmissio nDistance(k m)	Temperature Range (°C)	
XFP	LXF-L31-10D	10.3125	multi- mode fiber	1310	10	0~70	Commercial

I. Pin Diagram

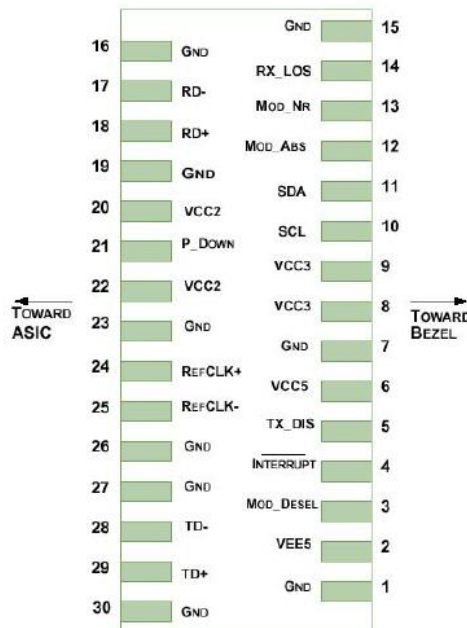

Diagram of Host Board Connector Block Pin Numbers and Name

II. Pin Descriptions

Pin	Logic	Symbol	Name/Description	Ref.
1		GND	Module Ground	1
2		VEE5	Optional -5.2 Power Supply – Not required	
3	LVTTL-I	Mod-Desel	Module De-select; When held low allows the module to respond to 2-wire serial interface commands	
4	LVTTL-O	Interrupt	Interrupt (bar); Indicates presence of an important condition which can be read over the serial 2-wire interface	2
5	LVTTL-I	TX_DIS	Transmitter Disable; Transmitter laser source turned off	
6		VCC5	+5 Power Supply – Not required	
7		GND	Module Ground	1
8		VCC3	+3.3V Power Supply	
9		VCC3	+3.3V Power Supply	
10	LCTTL-I	SCL	Serial 2-wire interface clock	2
11	LVTTL-I/O	SDA	Serial 2-wire interface data line	2
12	LVTTL-O	Mod_Abs	Module Absent; Indicates module is not present. Grounded in the module.	2
13	LVTTL-O	Mod_NR	Module Not Ready; Finisar defines it as a logical OR between RX_LOS and Loss of Lock ON TX/RX.	2
14	LVTTL-O	RX_LOS	Receiver Loss of Signal indicator	2
15		GND	Module Ground	1
16		GND	Module Ground	1
17	CML-O	RD-	Receiver inverted data output	
18	CML-O	RD+	Receiver non-inverted data output	
19		GND	Module Ground	1
20		VCC2	+1.8V Power Supply – Not required	
21	LVTTL-I	P_Down/RST	Power Down; When high, places the module in the low power stand-by mode and on the falling edge of P_Down initiates a module reset	
			Reset; The falling edge initiates a complete reset of the module including the 2-wire serial interface, equivalent to a power cycle.	
22		VCC2	+1.8V Power Supply – Not required	
23		GND	Module Ground	1
24	PECL-I	RefCLK+	Reference Clock non-inverted input, AC coupled on the host board – Not required	3
25	PECL-I	RefCLK-	Reference Clock inverted input, AC coupled on the host board – Not required	3
26		GND	Module Ground	1



Product specification

27		GND	Module Ground	1
Pin	Logic	Symbol	Name/Description	Ref.
28	CML-I	TD-	Transmitter inverted data input	
29	CML-I	TD+	Transmitter non-inverted data input	
30		GND	Module Ground	1

Notes:

1. Module circuit ground is isolated from module chassis ground within the module.
2. Open collector; should be pulled up with 4.7K – 10KΩ on host board to a voltage between 3.15V and 3.6V.
3. A Reference Clock input is not required by the IP-HGL-K10B31. If present, it will be ignored.

III. Absolute Maximum Ratings

Parameter	Symbol	Min.	Typ.	Max.	Unit	Ref.
Storage Temperature	TS	-40		85	°C	
Storage Ambient Relative Humidity	HA	0		85	%	
Power Supply Voltage	VCC	-0.5		4	V	
Signal Input Voltage		-0.3		Vcc+0.3	V	
Receiver Damage Threshold		+3			dBm	
Lead Soldering Temperature/Time	TSOLD			260/10	°C/sec	1
Lead Soldering Temperature/Time	TSOLD			360/10	°C/sec	2

Note:

1. Suitable for wave soldering.
2. Only for soldering by iron.

IV. Recommended Operating Conditions

Parameter	Symbol	Min.	Typ.	Max.	Unit	Ref.
Case Operating Temperature	Tcase	0		70	°C	LXF-L31-10D
Ambient Humidity	HA	5		70	%	Non-condensing
Data Rate			10.3125/10.3125		Gbps	TX Rate/RX Rate
Transmission Distance				10	km	
Coupled Fiber			Single-mode fiber			9/125um G.652

V. Optical Characteristics

Parameter	Symbol	Min.	Typ.	Max.	Unit	Ref.
Transmitter						
Average Output Power	POUT	-6		-1	dBm	
Extinction Ratio	ER	3.5			dB	
Center Wavelength	λ_C	1290	1310	1330	nm	
Sidemode Suppression Ratio	SSRmin	30			dB	
Transmitter and Dispersion Penalty	TDP			3.2	dB	
Transmitter OFF Output Power	POff			-30	dBm	
Optical Modulation Amplitude(OMA)	POMA	-4.8		0	dBm	
Relative Intensity Noise	RIN			-130	dB/Hz	
Receiver						
Input Optical Wavelength	λ_{IN}	1260		1600	nm	LXF-L31-10D
Rx Sensitivity	RSENS1			-14.4	dBm	1
Rx Sensitivity(OMA)	RSENS2			-10.3	dBm	2
Input Saturation Power (Overload)	PSAT	+0.5			dBm	
Loss of Signal Assert	PA	-32			dBm	
Loss of Signal De-assert	PD			-15.4	dBm	
LOS Hysteresis	PD - PA	0.5		6	dB	

Note:

1. Measured with worst ER; BER<10⁻¹²; 231 – 1 PRBS.
2. Per IEEE 802.3ae. Equivalent to –13.3 dBm average power at Infinite ER.

VI. General Specifications

Parameter	Symbol	Min.	Typ.	Max.	Unit	Ref.
Bit Rate	BR	8.5		10.5	Gb/s	1
Bit Error Ratio	BER			10-12		2

Note :

1. 10GBASE-LR/LW, 1200-SM-LL-L, 800-SM-LC-L, and 10G CPRI
2. Tested with a 231 – 1 PRBS

VII. Digital Diagnostic Memory Map

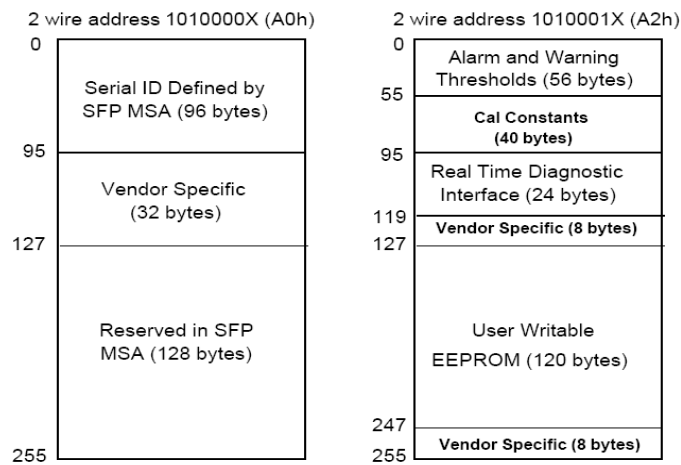

VIII. Digital Diagnostic Monitoring Information

Parameter	Unit	Accuracy
Case Temperature	°C	±3
Supply Voltage	V	±3%
Tx Bias Current	mA	±10%
Tx Optical Power	dB	±3
Rx Optical Power	dB	±3

IX. Electrical Interface Characteristics

Parameter	Symbol	Min.	Typ.	Max.	Unit	Ref.
Supply Voltage	VCC	3.13	3.30	3.47	V	
Supply Current	ICC			600	mA	
Module total power	P			1.5	W	1
Transmitter						
Input different impedance	Rin	90	100	110	Ω	2
Single ended data input swing	Vin,pp	120		820	mV	
Transmitter Disable Voltage	VDIS	2		VCC	V	
Transmitter Enable Voltage	VEN	0		0.8	V	
Receiver						
Output different impedance	Rout	90	100	110	Ω	2
Single ended data output swing	Vout,pp	340		850	mV	3
LOSAsserted	VLOSA	2		VCCHOST	V	4
LOSDe-asserted	VLOSD	0		0.8	V	4
Power Supply Rejection	PSR					5

Note :

1. Maximum total power value is specified across the full temperature and voltage range.
2. Connected directly to TX data input pins. AC coupled thereafter.
3. Into 100Ω differential termination.
4. LossOf Signal is LVTTTL. Logic “0” indicates normal operation; logic “1” indicates no signal detected.
5. Per Section 2.7.1. in the XFP MSA Specification.

X. Recommend Circuit Schematic

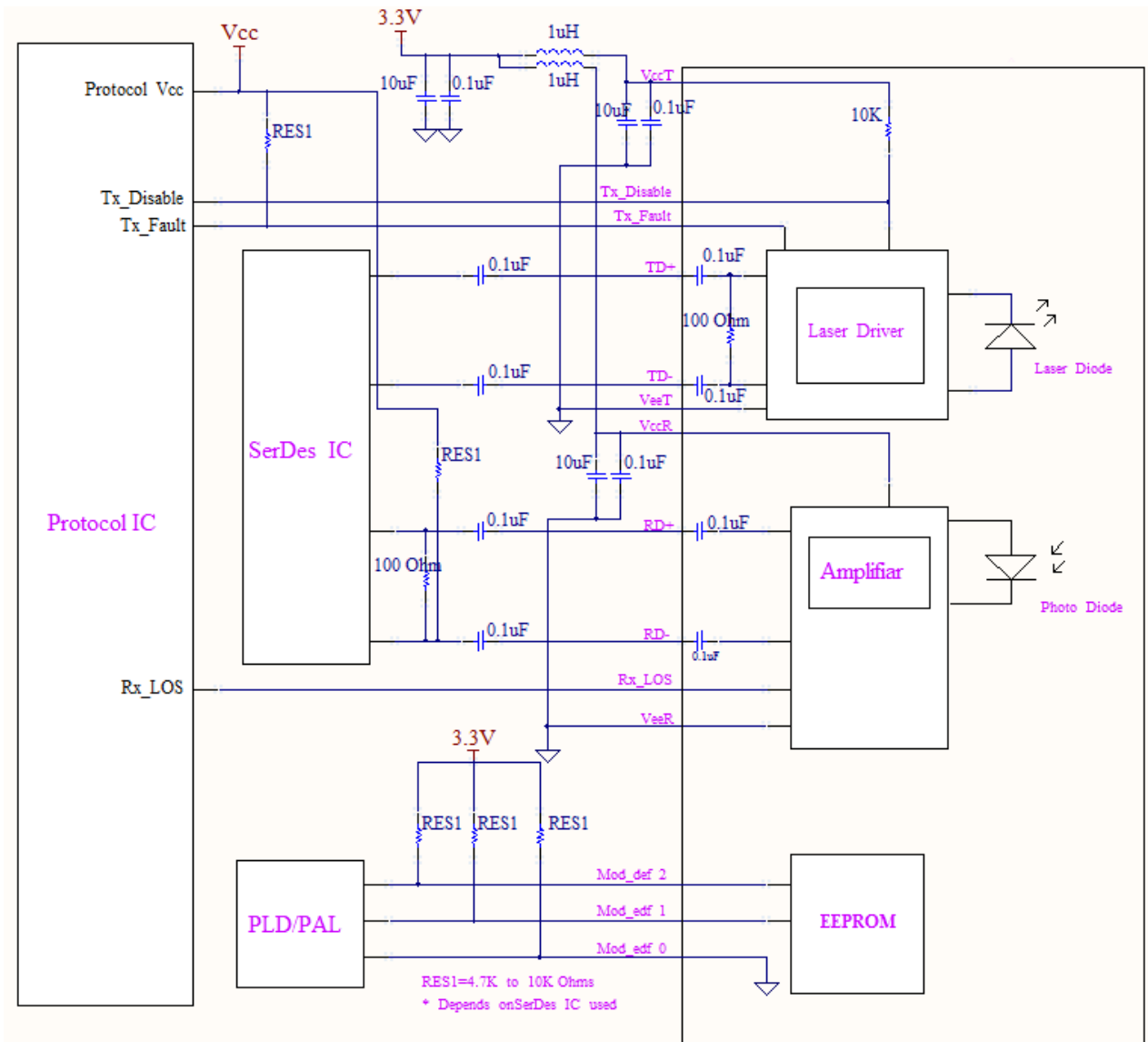

XI. Mechanical Specifications (Unit: mm)

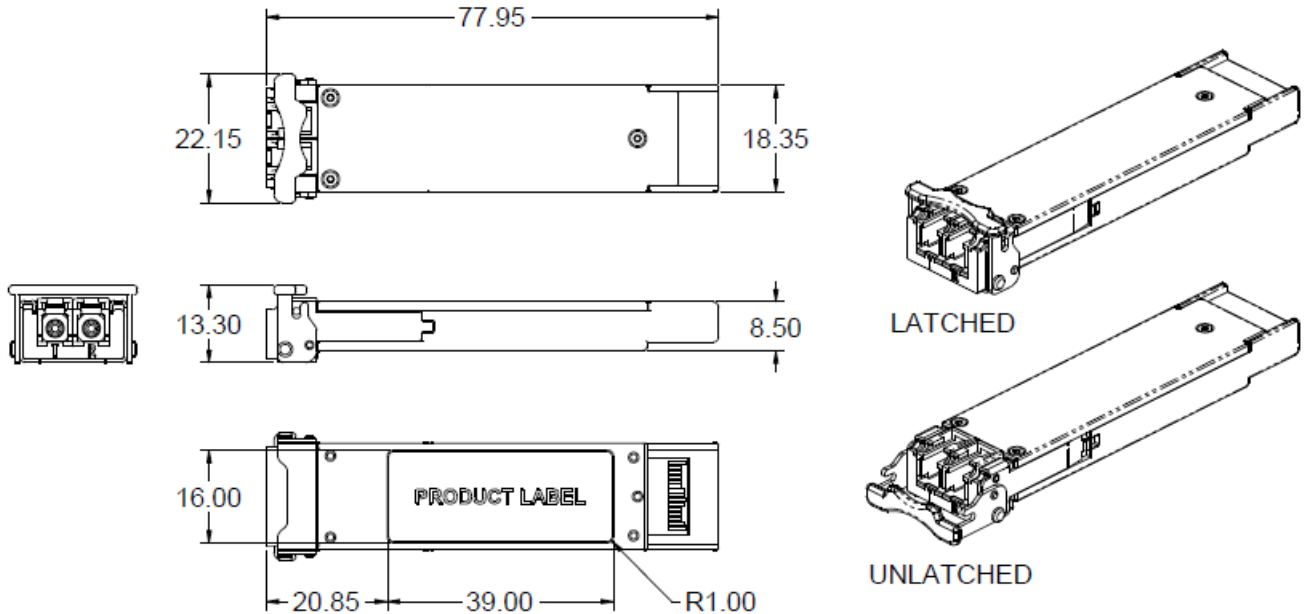

XFP Transceiver (dimensions are in mm)

LXF-L31-10D

XII. Regulatory Compliance

Feature	Reference	Performance
Electrostatic discharge (ESD)	IEC/EN 61000-4-2	Compatible with standards
Electromagnetic Interference (EMI)	FCC Part 15 Class B EN 55022 Class B (CISPR 22A)	Compatible with standards
Laser Eye Safety	FDA 21 CFR 1040.10, 1040.11 IEC/EN 60825-1,2	Class 1 laser product
Component Recognition	IEC/EN 60950, UL	Compatible with standards
ROHS	2002/95/EC	Compatible with standards
EMC	EN61000-3	Compatible with standards

Revision History



Product specification

Version No.	Date	Description
1.0	June 24, 2019	Preliminary datasheet