

LXP-Dxx-40D

SFP+ 10Gb/s DWDM Single-mode 40km DDM

PRODUCT FEATURES

- Up to 11.3Gbps Data Links
- DWDM EML laser transmitter and PIN/TIA receiver
- Up to 40km on 9/125µm SMF
- Hot-pluggable SFP footprint
- Duplex LC/UPC type pluggable optical interface
- Low power dissipation
- Metal enclosure, for lower EMI
- RoHS compliant and lead-free
- Support Digital Diagnostic Monitor interface
- Single +3.3V power supply
- Compliant with SFF-8472
- Case operating temperature
Commercial: 0°C to +70°C



APPLICATIONS

- 10GBASE-ER/EW & 10G Ethernet

Compliance

- SFF-8472 SFP+ MSA.
- SFP+ SFF-8431 and SFF-8432.
- IEEE802.3ae
- RoHS

PRODUCT DESCRIPTION

LXP-Dxx-40D SFP+ transceivers are compatible with the Small Form Factor Pluggable Multi-Sourcing Agreement (MSA). The transceiver consists of five sections: the LD driver, the limiting amplifier, the digital diagnostic monitor, the DWDM EML Laser and the PIN/TIA. The module data link up to 40km in 9/125um Single-mode fiber.

This transceiver meets the SFP+ industry standard package utilizing an integral LC-Duplex optical interface connector. An enhanced Digital Diagnostic Monitoring Interface compliant with SFF-8472 has been incorporated into the transceiver. It allows real time access to the transceiver operating parameters such as transceiver temperature, laser bias current, transmitted optical power, received optical power and transceiver supply voltage by reading a built-in memory with I²C interface.

The optical output can be disabled by a LVTTTL logic high-level input of Tx Disable, and the system also can disable the module via I²C. Tx Fault is provided to indicate that degradation of the laser. Loss of signal (LOS) output is provided to indicate the loss of an input optical signal of receiver or the link status with partner. The system can also get the LOS (or Link)/Disable/Fault information via I²C register access.

Ordering information

Package	Product part NO.	Data Rate(G bps)	Media	Wavelength(nm)	Transmission Distance(km)	Temperature Range (°C)	
SFP+	LXP-Dxx-40D	10.3125	single-mode fiber	1xx0	40	0~70	Commercial

LXP-Dxx-40D:

C-band λ_c Wavelength Guide Pin Descriptions

Channel	Wavelength(nm)	Frequency(THZ)	Channel	Wavelength(nm)	Frequency(THZ)
C17	1563.86	191.70	C39	1546.12	193.90
C18	1563.05	191.80	C40	1545.32	194.00
C19	1562.23	191.90	C41	1544.53	194.10
C20	1561.42	192.00	C42	1543.73	194.20
C21	1560.61	192.10	C43	1542.94	194.30
C22	1559.79	192.20	C44	1542.14	194.40
C23	1558.98	192.30	C45	1541.35	194.50
C24	1558.17	192.40	C46	1540.56	194.60
C25	1557.36	192.50	C47	1539.77	194.70
C26	1556.55	192.60	C48	1538.98	194.80
C27	1555.75	192.70	C49	1538.19	194.90
C28	1554.94	192.80	C50	1537.40	195.00
C29	1554.13	192.90	C51	1536.61	195.10
C30	1553.33	193.00	C52	1535.82	195.20
C31	1552.52	193.10	C53	1535.04	195.30
C32	1551.72	193.20	C54	1534.25	195.40
C33	1550.92	193.30	C55	1533.47	195.50
C34	1550.12	193.40	C56	1532.68	195.60
C35	1549.32	193.50	C57	1531.90	195.70
C36	1548.51	193.60	C58	1531.12	195.80
C37	1547.72	193.70	C59	1530.33	195.90
C38	1546.92	193.80	C60	1529.55	196.00
			C61	1528.77	196.10

I. Pin Diagram

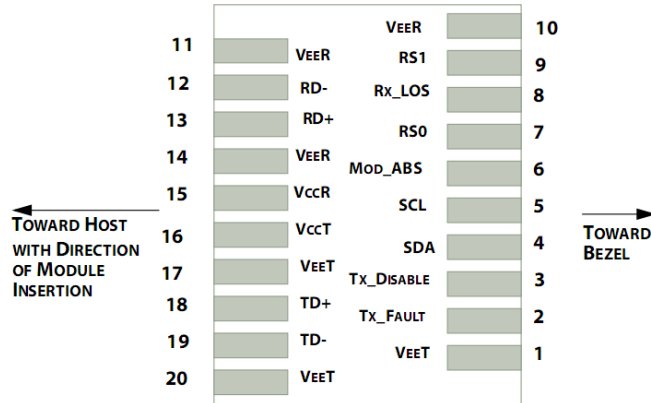

Pinout of Connector Block on Host Board

II. Pin Descriptions

Pin	Symbol	Name/Description	Ref.
1	V_{EET}	Transmitter Ground (Common with Receiver Ground)	1
2	T_{FAULT}	Transmitter Fault.	2
3	T_{DIS}	Transmitter Disable. Laser output disabled on high or open.	3
4	SDA	2-wire Serial Interface Data Line	4
5	SCL	2-wire Serial Interface Clock Line	4
6	MOD_ABS	Module Absent. Grounded within the module	4
7	RS0	No connection required	
8	LOS	Loss of Signal indication. Logic "0" indicates normal operation.	5
9	RS1	No connection required	
10	V_{EER}	Receiver Ground (Common with Transmitter Ground)	1
11	V_{EER}	Receiver Ground (Common with Transmitter Ground)	1
12	RD-	Receiver Inverted DATA out. AC Coupled	
13	RD+	Receiver Non-inverted DATA out. AC Coupled	
14	V_{EER}	Receiver Ground (Common with Transmitter Ground)	1
15	V_{CCR}	Receiver Power Supply	
16	V_{CCT}	Transmitter Power Supply	
17	V_{EET}	Transmitter Ground (Common with Receiver Ground)	1
18	TD+	Transmitter Non-Inverted DATA in. AC Coupled.	
19	TD-	Transmitter Inverted DATA in. AC Coupled.	
20	V_{EET}	Transmitter Ground (Common with Receiver Ground)	1

Notes:

1. Circuit ground is internally isolated from chassis ground.
2. TX Fault is an open drain output, which should be pulled up with 4.7K – 10K Ω resistor on the host board. Pull up voltage between 2.0V to $V_{ccT/R}+0.3V$. When high, output indicates a laser fault of some kind. Low indicates normal operation. In the low state, the output will be pulled to $< 0.8V$. When sensing an improper power level in the laser driver, the SFP sets this signal high and turns off the laser. TX-FAULT can be reset with the TX-DISABLE line. The signal is in LVTTTL level.
3. TX disable is an input that is used to shut down the transmitter optical output. It is pulled up within the module with 4.7K – 10K Ω resistor. Its states are: Low (0 – 0.8V): Transmitter on; ($>0.8, < 2.0V$): Undefined; High (2.0V to $V_{ccT/R}+0.3V$): Transmitter Disabled; Open: Transmitter Disabled. The TX-DISABLE signal is high (LVTTTL logic “1”) to turn off the laser output. The laser will turn on when TX-DISABLE is low (LVTTTL logic “0”).
4. Should be pulled up with 4.7K - 10K Ω on host board to a voltage between 2.0V to $V_{ccT/R}+0.3V$. MOD_ABS pulls line low to indicate module is plugged in.
5. LOS (Loss of Signal) is an open collector/drain output, which should be pulled up with 4.7K – 10K Ω resistor. Pull up voltage between 2.0V to $V_{ccT/R}+0.3V$. When high, this output indicates the received optical power is below the worst-case receiver sensitivity (as defined by the standard in use). Low indicates normal operation. In the low state, the output will be pulled to $< 0.8V$.

The RX-LOS is high (LVTTTL logic “1”) when there is no incoming light from the companion transceiver. This signal is normally used by the system for the diagnostic purpose. The signal is operated in LVTTTL level.

III. Absolute Maximum Ratings

Parameter	Symbol	Min.	Typ.	Max.	Unit	Ref.
Storage Temperature	T _s	-40		85	°C	
Storage Ambient Relative Humidity	H _A	0		85	%	
Power Supply Voltage	V _{CC}	-0.5		4	V	
Signal Input Voltage		-0.3		V _{CC} +0.3	V	
Receiver Damage Threshold		+3			dBm	
Lead Soldering Temperature/Time	TSOLD			260/10	°C/sec	Note (1)
Lead Soldering Temperature/Time	TSOLD			360/10	°C/sec	Note (2)

Note (1): Suitable for wave soldering.

Note (2): Only for soldering by iron.

IV. Recommended Operating Conditions

Parameter	Symbol	Min.	Typ.	Max.	Unit	Ref.
Case Operating Temperature	T _{case}	0		70	°C	LXP-Dxx-40D
Ambient Humidity	H _A	5		70	%	Non-condensing
Data Rate			10.3125/10.3125		Gbps	TX Rate/RX Rate
Transmission Distance				40	km	
Coupled Fiber	Singlemode fiber					9/125um G.652

V. Optical Characteristics

Parameter	Symbol	Min.	Typ.	Max.	Unit	Ref.
Transmitter						
Average Output Power	P_{OUT}	-1		+4	dBm	
Extinction Ratio	ER	8.2			dB	
Center Wavelength	λ_C	$\lambda_C-0.2$	λ_C	$\lambda_C+0.2$	nm	Note (1)
Side Mode Suppression Ratio	SMSR	30			dBm	
Spectrum Width (RMS)	σ			1	nm	
Transmitter OFF Output Power	P_{Off}			-30	dBm	
Output Eye Mask	Compatible with IEEE 802.3ae					
Receiver						
Input Optical Wavelength	λ_{IN}	1260		1610	nm	LXP-Dxx-40D
Rx Sensitivity	R_{SENS}			-16	dBm	Note (2)
Input Saturation Power (Overload)	$PSAT$	-3			dBm	
Loss of Signal Assert	P_A	-45			dBm	
Loss of Signal De-assert	P_D			-17	dBm	
LOS Hysteresis	$P_D - P_A$	0.5		6	dB	

Note (1): λ_C refer to wavelength selection, and corresponds to approximately 0.8 nm.

Note (2): With worst-case extinction ratio. Measured with a PRBS 2³¹-1 test pattern, @10.3125Gb/s, BER<10⁻¹².

VI. Digital Diagnostic Memory Map

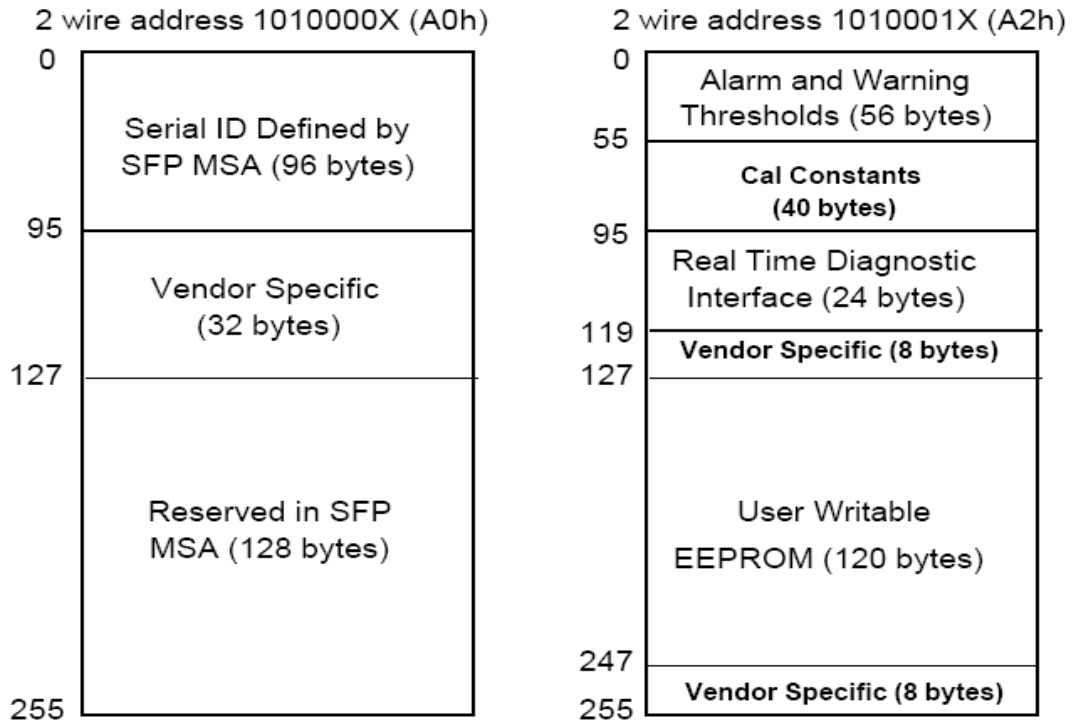

VII. Digital Diagnostic Monitoring Information

Parameter	Unit	Accuracy
Case Temperature	°C	±3
Supply Voltage	V	±3%
Tx Bias Current	mA	±10%
Tx Optical Power	dB	±3
Rx Optical Power	dB	±3

VIII. Electrical Interface Characteristics

Parameter	Symbol	Min.	Typ.	Max.	Unit	Ref.
Supply Voltage	V_{CC}	3.13	3.30	3.47	V	
Supply Current	I_{CC}			460	mA	
Transmitter						
Input different impedance	R_{in}	90	100	110	Ω	Note (1)
Single ended data input swing	$V_{in,pp}$	180		700	mV	
Transmitter Disable Voltage	V_{DIS}	2		V_{CC}	V	
Transmitter Enable Voltage	V_{EN}	0		0.8	V	
Receiver						
Output different impedance	R_{out}	90	100	110	Ω	Note (1)
Single ended data output swing	$V_{out,pp}$	300		850	mV	Note (2)
LOSAsserted	V_{LOSA}	2		V_{CCHOST}	V	Note (3)
LOSDe-asserted	V_{LOSD}	0		0.8	V	Note (3)

Note (1): Connected directly to TX data input pins. AC coupled thereafter.

Note (2): Into 100 Ω differential termination.

Note (3): LossOf Signal is LVTTTL. Logic "0" indicates normal operation; logic "1" indicates no signal detected.

IX. Recommend Circuit Schematic

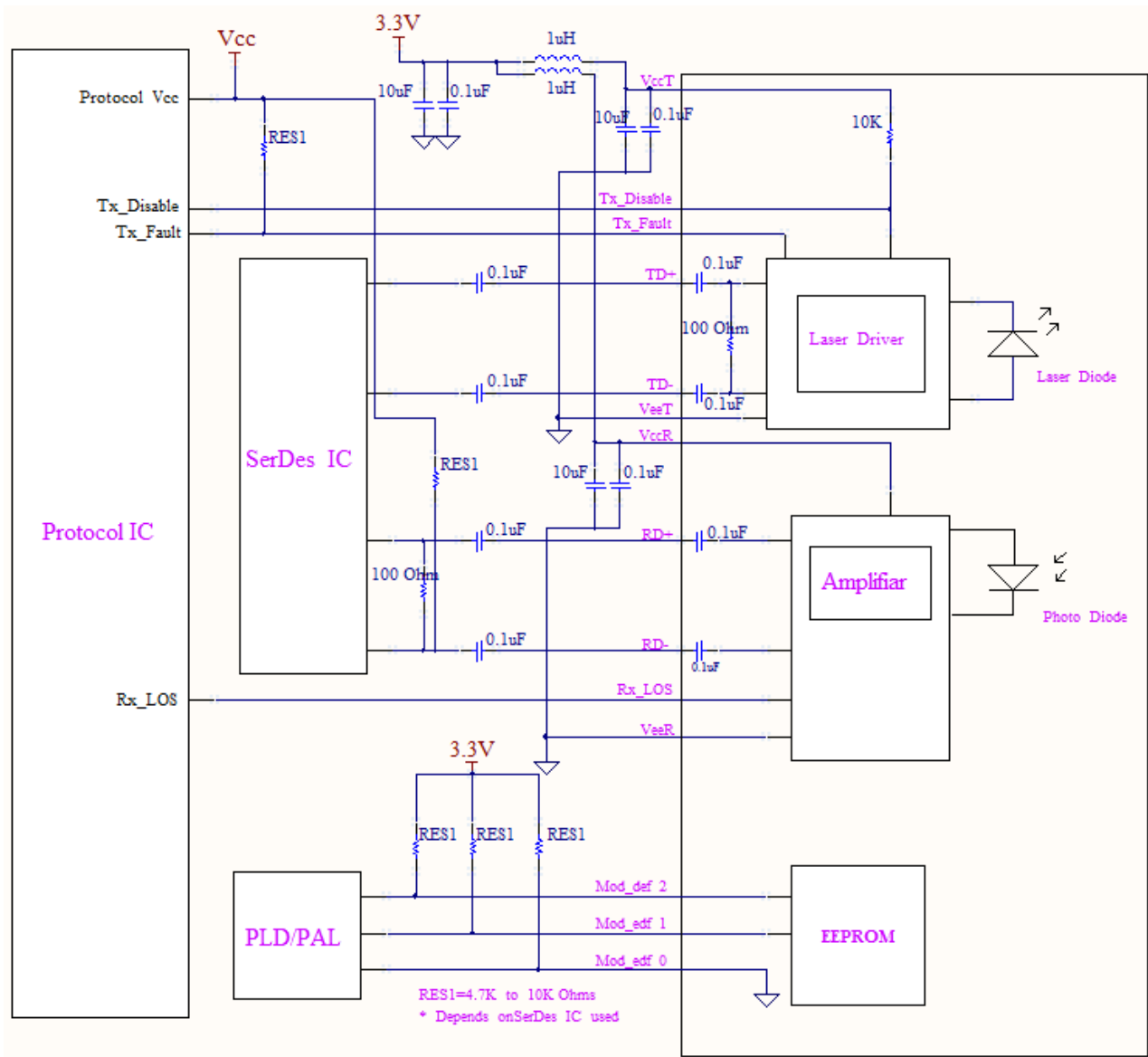

X. Mechanical Specifications (Unit: mm)

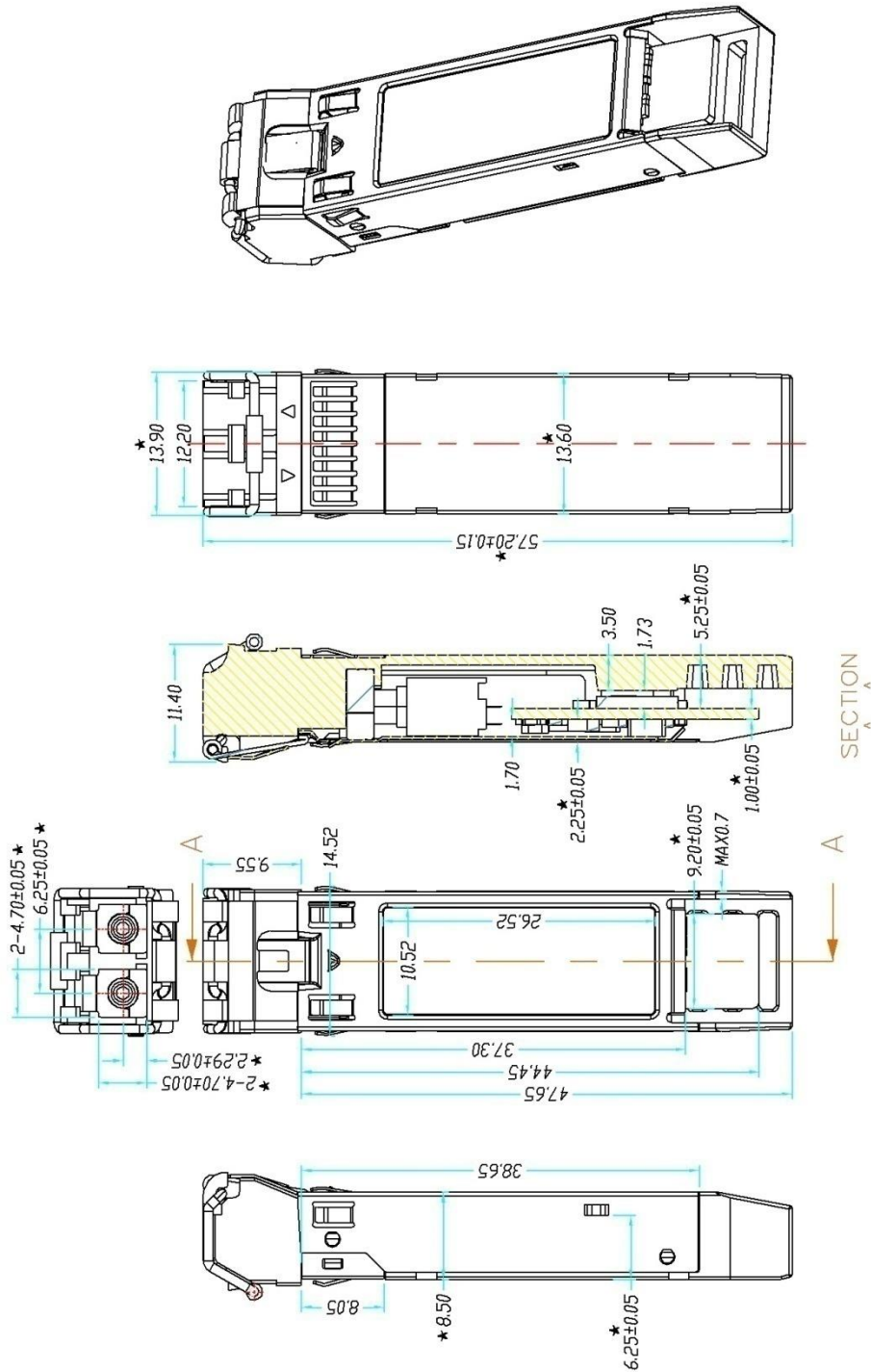

LXP-Dxx-40D

XI. Regulatory Compliance

Feature	Reference	Performance
EMC	EN61000-3	Compatible with standards
Electrostatic Discharge (ESD)	IEC/EN 61000-4-2	Compatible with standards
Electromagnetic Interference (EMI)	FCC Part 15 Class B EN 55022 Class B (CISPR 22A)	Compatible with standards
Laser Eye Safety	FDA 21CFR 1040.10, 1040.11 IEC/EN 60825-1 ,EC/EN 60825-2	Class 1 laser product
Component Recognition	IEC/EN 60950 ,L 60950	Compatible with standards
ROHS	2002/95/EC	Compatible with standards

Revision History

Version No.	Date	Description
1.0	June 24, 2019	Preliminary datasheet