

LGP-L31-10D

SFP 1.25Gb/s 1310nm Single-mode 10(20)km DDM

PRODUCT FEATURES

- Up to 1.25Gb/s data links
- 1310nm FP laser transmitter and PIN/TIA receiver
- Up to 10(20)km on 9/125µm SMF
- Hot-pluggable SFP footprint
- Duplex LC/UPC type pluggable optical interface
- Low power dissipation
- Metal enclosure, for lower EMI
- RoHS compliant and lead-free
- Support Digital Diagnostic Monitor interface
- Single +3.3V power supply
- Compliant with SFF-8472
- Case operating temperature
Commercial: 0°C to +70°C



APPLICATIONS

- Switch to Switch Interface
- Fast Ethernet
- Switched Backplane Applications
- Router/Server Interface
- Other Optical Links

Compliance

- SFP MSA
- SFF-8472
- IEEE802.3z
- RoHS

PRODUCT DESCRIPTION

LGP-L31-10D Small Form Factor Pluggable (SFP) transceivers are compatible with the Small Form Factor Pluggable Multi-Sourcing Agreement (MSA). The transceiver consists of five sections: the LD driver, the limiting amplifier, the digital diagnostic monitor, the 1310nm FP laser and the PIN/TIA. The module data link up to 20km in 9/125um Single-mode fiber.

This transceiver meets the Small Form Pluggable (SFP) industry standard package utilizing an integral LC-Duplex optical interface connector. An enhanced Digital Diagnostic Monitoring Interface compliant with SFF-8472 has been incorporated into the transceiver. It allows real time access to the transceiver operating parameters such as transceiver temperature, laser bias current, transmitted optical power, received optical power and transceiver supply voltage by reading a built-in memory with I2C interface.

The optical output can be disabled by a LVTTTL logic high-level input of Tx Disable, and the system also can disable the module via I2C. Tx Fault is provided to indicate that degradation of the laser. Loss of signal (LOS) output is provided to indicate the loss of an input optical signal of receiver or the link status with partner. The system can also get the LOS (or Link)/Disable/Fault information via I2C register access.

Ordering information

Package	Product part NO.	Data Rate (Mbps)	Media	Wavelength (nm)	Transmission Distance (km)	Temperature Range (°C)	
SFP	LGP-L31-10D	1250	single-mode fiber	1310	10(20)	0~70	Commercial

I. Pin Diagram

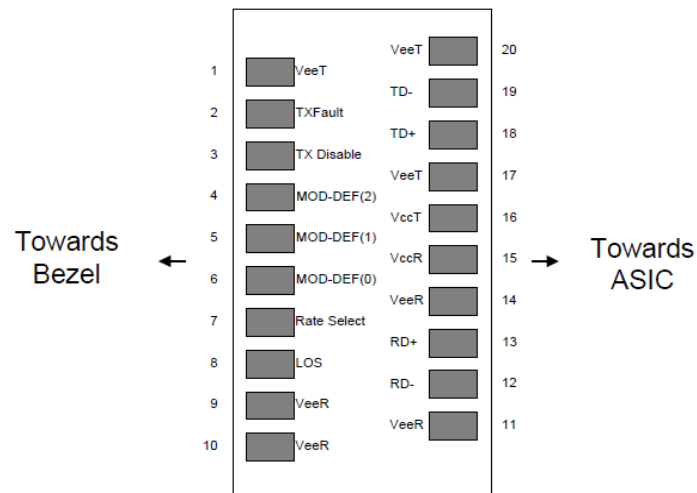

Pinout of Connector Block on Host Board

II. Pin Descriptions

Pin	Symbol	Name/Description	Ref.
1	V _{EET}	Transmitter Ground (Common with Receiver Ground)	1
2	T _{FAULT}	Transmitter Fault. Open Drain. Logic "0" indicates normal operation.	2
3	T _{DIS}	Transmitter Disable. Laser output disabled on high or open.	3
4	MOD_DEF(2)	Module Definition 2. Data line for Serial ID.	4
5	MOD_DEF(1)	Module Definition 1. Clock line for Serial ID.	4
6	MOD_DEF(0)	Module Definition 0. Grounded within the module.	4
7	Rate Select	No connection required.	
8	LOS	Loss of Signal indication. Open Drain. Logic "0" indicates normal operation.	5
9	V _{EER}	Receiver Ground (Common with Transmitter Ground)	1
10	V _{EER}	Receiver Ground (Common with Transmitter Ground)	1
11	V _{EER}	Receiver Ground (Common with Transmitter Ground)	1
12	RD-	Receiver Inverted DATA out(CML). AC Coupled	
13	RD+	Receiver Non-inverted DATA out(CML). AC Coupled	
14	V _{EER}	Receiver Ground (Common with Transmitter Ground)	1
15	V _{CCR}	Receiver Power Supply	
16	V _{CCT}	Transmitter Power Supply	
17	V _{EET}	Transmitter Ground (Common with Receiver Ground)	1
18	TD+	Transmitter Non-Inverted DATA in. AC Coupled.	
19	TD-	Transmitter Inverted DATA in. AC Coupled.	
20	V _{EET}	Transmitter Ground(Common with Receiver Ground)	1

Notes:

1. Circuit ground is internally isolated from chassis ground.
2. TX Fault is an open drain output, which should be pulled up with 4.7K – 10KΩ resistor on the host board. Pull up voltage between 2.0V to $V_{ccT/R}+0.3V$. When high, output indicates a laser fault of some kind. Low indicates normal operation. In the low state, the output will be pulled to $< 0.8V$. When sensing an improper power level in the laser driver, the SFP sets this signal high and turns off the laser. TX-FAULT can be reset with the TX-DISABLE line. The signal is in LVTTTL level.
3. TX disable is an input that is used to shut down the transmitter optical output. It is pulled up within the module with 4.7K – 10KΩ resistor. Its states are: Low (0 – 0.8V): Transmitter on; ($>0.8, < 2.0V$): Undefined; High ($2.0V$ to $V_{ccT/R}+0.3V$): Transmitter Disabled; Open: Transmitter Disabled. The TX-DISABLE signal is high (LVTTTL logic “1”) to turn off the laser output. The laser will turn on when TX-DISABLE is low (LVTTTL logic “0”).
4. Should be pulled up with 4.7K - 10KΩ on host board to a voltage between 2.0V to $V_{ccT/R}+0.3V$. MOD_DEF(0) pulls line low to indicate module is plugged in.
5. LOS (Loss of Signal) is an open collector/drain output, which should be pulled up with 4.7K – 10KΩ resistor. Pull up voltage between 2.0V to $V_{ccT/R}+0.3V$. When high, this output indicates the received optical power is below the worst-case receiver sensitivity (as defined by the standard in use). Low indicates normal operation. In the low state, the output will be pulled to $< 0.8V$.

The RX-LOS is high (LVTTTL logic “1”) when there is no incoming light from the companion transceiver. This signal is normally used by the system for the diagnostic purpose. The signal is operated in LVTTTL level.

III. Absolute Maximum Ratings

Parameter	Symbol	Min.	Typ.	Max.	Unit	Ref.
Storage Temperature	T_s	-40		85	°C	
Storage Ambient Relative Humidity	H_A	0		85	%	
Power Supply Voltage	V_{cc}	-0.5		4	V	
Signal Input Voltage		-0.3		$V_{cc}+0.3$	V	
Receiver Damage Threshold		+3			dBm	
Lead Soldering Temperature/Time	TSOLD			260/10	°C/sec	Note (1)
Lead Soldering Temperature/Time	TSOLD			360/10	°C/sec	Note (2)

Note (1): Suitable for wave soldering.

Note (2): Only for soldering by iron.

IV. Recommended Operating Conditions

Parameter	Symbol	Min.	Typ.	Max.	Unit	Ref.
Case Operating Temperature	T _{case}	0		70	°C	LGP-L31-10D
Ambient Humidity	H _A	5		70	%	Non-condensing
Power Supply Voltage	V _{CC}	3.13	3.3	3.47	V	
Power Supply Current	I _{CC}			280	mA	
Data Rate			1250/1250		Mbps	TX Rate/RX Rate
Transmission Distance				20	km	
Coupled Fiber	Singlemode fiber					9/125um G.652

V. Specification of Transmitter

Parameter	Symbol	Min.	Typ.	Max.	Unit	Ref.
Average Output Power	P _{OUT}	-9		-3	dBm	
Extinction Ratio	ER	9			dB	
Center Wavelength	λ _C	1260	1310	1360	nm	LGP-L31-10D
Spectrum Bandwidth(RMS)	σ			3.5	nm	FP Laser
Transmitter OFF Output Power	P _{OFF}			-45	dBm	
Jitter p-p	t _J			0.1	UI	Note (1)
Output Eye Mask	Compliant with IEEE802.3z (class 1 laser safety)					Note (2)

Note (1): Measure at 2⁷-1 NRZ PRBS pattern.

Note (2): Transmitter eye mask definition.

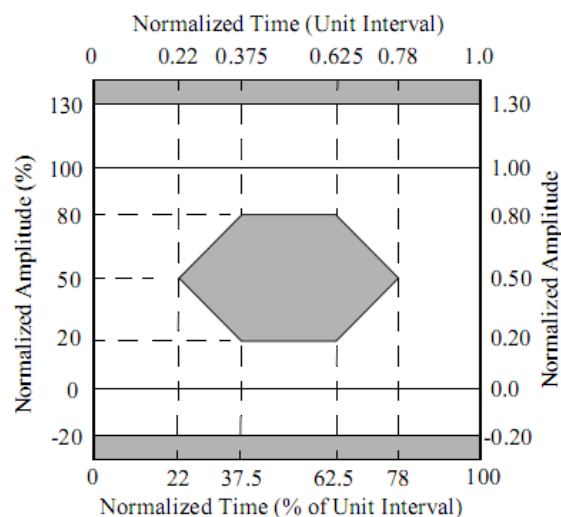

VI. Specification of Receiver

Parameter	Symbol	Min.	Typ.	Max.	Unit	Ref.
Input Optical Wavelength	λ_{IN}	1270		1610	nm	LGP-L31-10D
Receiver Sensitivity	PIN			-24	dBm	Note (1)
Input Saturation Power (Overload)	PSAT	-3			dBm	
Loss of Signal Assert	PA	-45			dBm	
Loss of Signal De-assert	PD			-24.5	dBm	Note (2)
LOS Hysteresis	PD-PA	0.5		6	dB	

Note (1): Measured with Light source 1310nm, ER=9dB; BER = $<10^{-12}$ @ PRBS=2⁷-1 NRZ

Note (2): When LOS De-asserted, the RX data +/- output is signal output.

VII. Digital Diagnostic Memory Map

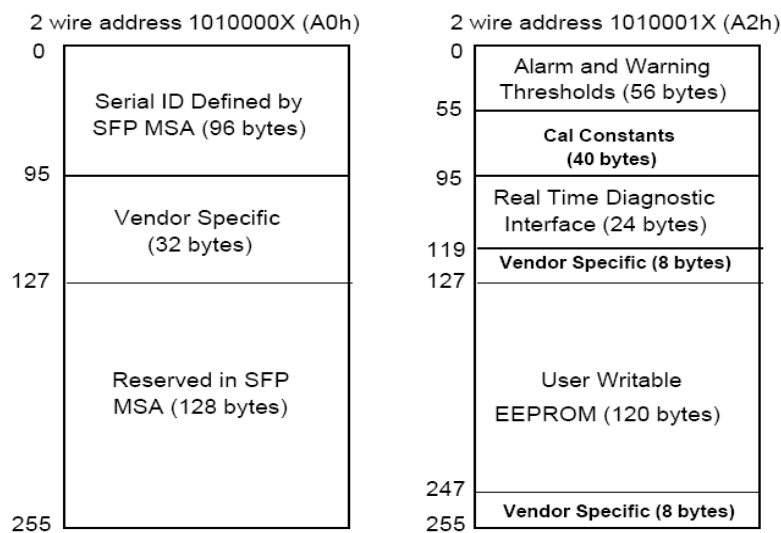

VIII. Digital Diagnostic Monitoring Information

Parameter	Unit	Accuracy
Case Temperature	°C	±3
Supply Voltage	V	±3%
Tx Bias Current	mA	±10%
Tx Optical Power	dB	±3
Rx Optical Power	dB	±3

IX. Electrical Interface Characteristics

Parameter	Symbol	Min.	Typ.	Max.	Unit	Ref.
Transmitter						
Total Supply Current	ICC			A	mA	Note (1)
Transmitter Disable Input-High	VDISH	2		V _{cc} +0.3	V	LVTTTL
Transmitter Disable Input-Low	VDISL	0		0.8	V	
Transmitter Fault Input-High	VTxFH	2		V _{cc} +0.3	V	
Transmitter Fault Input-Low	VTxFL	0		0.8	V	
Receiver						
Total Supply Current	ICC			B	mA	Note (1)
LOS Output Voltage-High	VLOSH	2		V _{cc} +0.3	V	LVTTTL
LOS Output Voltage-Low	VLOSL	0		0.8	V	

Note (1): A (TX)+ B (RX) = 280mA (Not include termination circuit)

X. Recommend Circuit Schematic

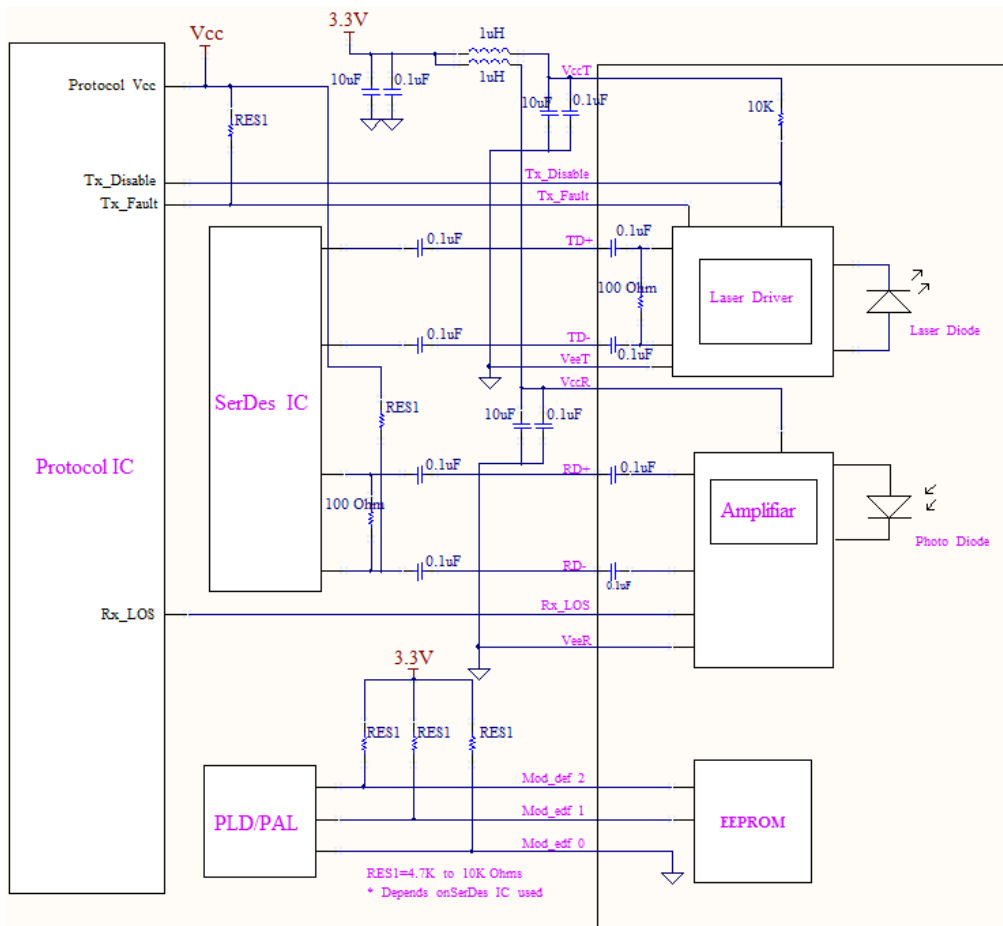

XI. Mechanical Specifications(Unit: mm)

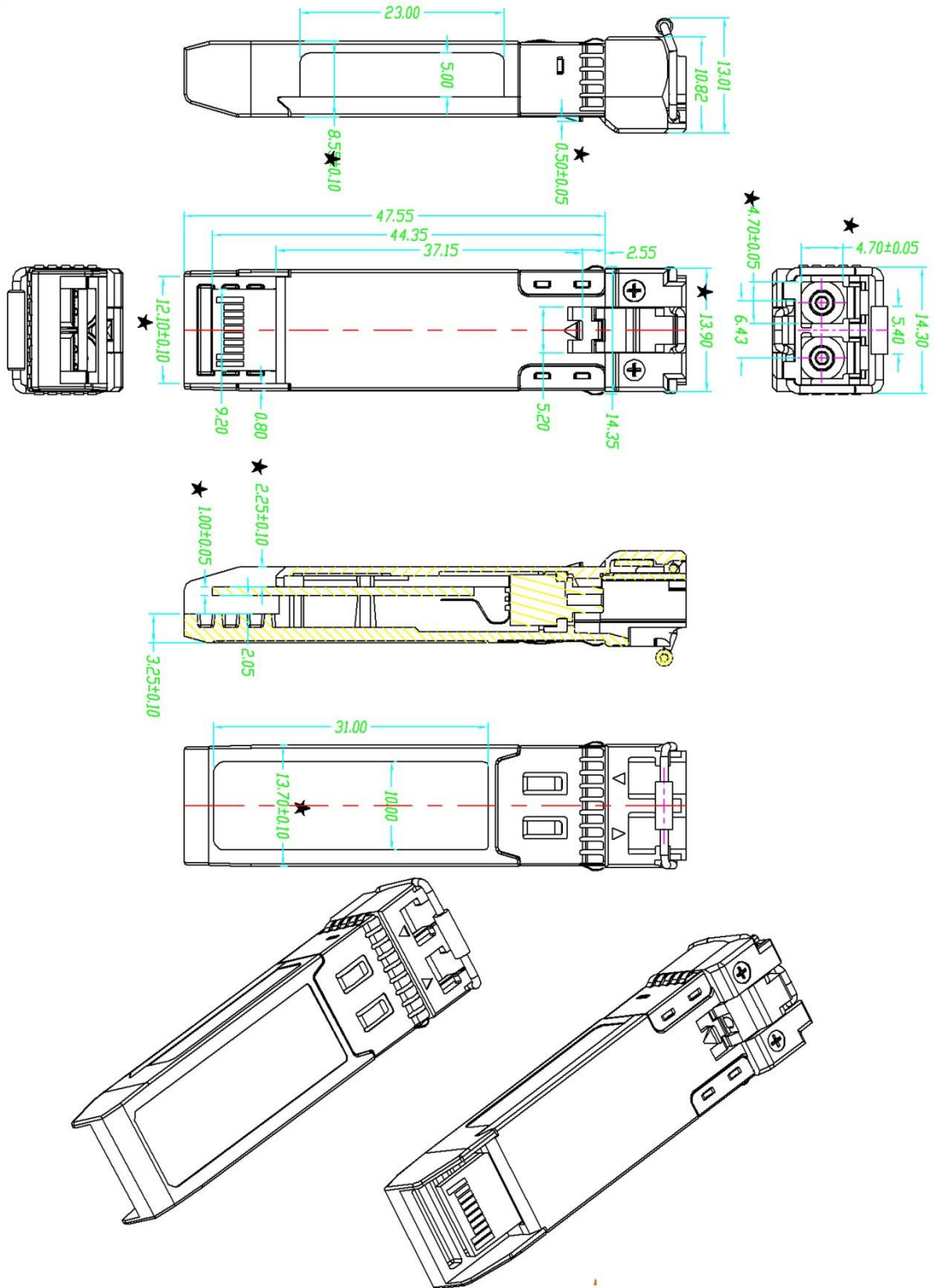

LGP-L31-10D

XII. Regulatory Compliance

Feature	Reference	Performance
EMC	EN61000-3	Compatible with standards
Electrostatic Discharge (ESD)	IEC/EN 61000-4-2	Compatible with standards
Electromagnetic Interference (EMI)	FCC Part 15 Class B EN 55022 Class B (CISPR 22A)	Compatible with standards
Laser Eye Safety	FDA 21CFR 1040.10, 1040.11 IEC/EN 60825-1 ,EC/EN 60825-2	Class 1 laser product
Component Recognition	IEC/EN 60950 ,L 60950	Compatible with standards
ROHS	2002/95/EC	Compatible with standards

Revision History

Version No.	Date	Description
1.0	June 24, 2019	Preliminary datasheet