

LQP100-LX4

QSFP28 100Gbps LX4 2km(SMF)@100m(MMF@OM3) DDM Transceiver

PRODUCT FEATURES

- QSFP28 MSA compliant
- Supports 103.1 Gb/s aggregate bit rate
- 4x25Gb/s electrical interface
- Up to 2km on SMF and 100m on MMF(OM3)
- Hot-pluggable QSFP28 footprint
- LC duplex connector
- Maximum power consumption 3.5 Watts
- Single 3.3V power supply
- Support Digital Diagnostic Monitor interface
- Case operating temperature:0°C to +70°C
- RoHS compliant

APPLICATIONS

- 100GBASE-LX4 Ethernet
- Data Center Interconnect

COMPLIANCE

- SFF-8636
- IEEE802.3
- RoHS

PRODUCT DESCRIPTION

LQP100-LX4 is designed for 2km on SMF and 0.1km on MMF(OM3) optical communication applications. This module contains 4-lane DFB optical transmitter, 4-lane optical receiver and module management block including 2 wire serial interfaces. The optical signals are multiplexed to a single-mode fiber through an industry standard LC connector.

Ordering Information

Part Number	Data Rate (Gb/s)	Media	Wavelength(nm)	Operating distance(km)	Temperature
LQP100-LX4	103.1	SMF MMF	CWDM	SMF:2km MMF:100m@OM3	0~70

I. Absolute Maximum Ratings

It has to be noted that the operation in excess of any individual absolute maximum ratings might cause permanent damage to this module.

Parameter	Symbol	Min	Typical	Max	Unit	Notes
Maximum Supply Voltage	V _{cc}	0		3.6	V	
Storage Temperature	T _s	-40		85	°C	
Operating Case Temperature	T _{case}	-5		75	°C	
Relative Humidity	RH	5		85	%	
Damage threshold,per lane	P _{dam}	3.6			dBm	

II. Recommended Operating Conditions

Parameter	Symbol	Min	Typical	Max	Unit	Notes
Operating Case Temperature	T _{case}	0		70	°C	
Supply Voltage	V _{CC}	3.135	3.3	3.465	V	
Relative Humidity	R _H	5		85	%	
Power Dissipation	P _D			3.5	W	
Data Rate (optical)	DR _O		4*25.78125		Gbps	
Data Rate (Electrical)	DR _E		4*25.78125		Gbps	
Operating Link Distance	L _D		SMF:2 MMF:0.1@OM3		km	

III. Optical Characteristics

100GBASE-LX4 Operation (EOL, TOP = 0 ~70 °C ,VCC = 3.135 to 3.465 V)

Parameters	Symbol	Min	Typical	max	Unit	Note
Transmitter						
Signal Speed per Lane	BR	25.78125 ± 100 ppm			Gb/s	
Transmit wavelength	λ0	1264.5	1271	1277.5	nm	
	λ1	1284.5	1291	1297.5	nm	
	λ2	1304.5	1311	1317.5	nm	
	λ3	1324.5	1331	1337.5	nm	
Side-Mode Suppression Ratio	SMSR	30			dB	
Total Average Launch Power for SMF	P _{total}			8.5	dBm	
Total Average Launch Power for MMF				9.5	dBm	
Average launch power per lane for SMF	P _{out}	-6.5		2.5	dBm	
Average launch power per lane for MMF		-5.0		3.5	dBm	
Transmit OMA per Lane for SMF	TxOMA	-4.0		2.5	dBm	
Transmit OMA per Lane for MMF		-4.0		3.5	dBm	
Launch power OFF per lane	POff			-30	dBm	
Transmitter and Dispersion Penalty (TDP), each lane	TDP			3	dB	
Extinction Ratio (ER)	ER	3.5			dB	
RIN20 OMA	RIN			-128	dB/Hz	
Transmitter eye mask definition {X1,X2, X3, Y1, Y2, Y3}	{0.31, 0.40, 0.45, 0.34, 0.38, 0.4}					1
Mask margin		15			%	1
Receiver						
Signaling Speed per Lane	BR	10.3125 ± 100 ppm			Gb/s	
Receive wavelength	λ0	1264.5	1271	1277.5	nm	
	λ1	1284.5	1291	1297.5	nm	
	λ2	1304.5	1311	1317.5	nm	
	λ3	1324.5	1331	1337.5	nm	
Damage threshold, each lane	Pmax			3.5	dBm	
Average receive power per lane for SMF		-11.5		2.5	dBm	
Average receive power per lane for MMF		-8.6		3.5	dBm	
Rx Sensitivity (OMA) per lane for SMF	R _{SEN}			-8.6	dBm	
Rx Sensitivity (OMA) per lane for MMF				-8.6	dBm	
Receiver reflectance	Rfl			-26	dB	
LOS Assert	LOSA	-30			dBm	
LOS De-Assert	LOSD			-12.5	dBm	
LOS Hysteresis		0.5		6	dB	

Notes

 1. Hit ratio 5 × 10⁻⁵.

IV. Electrical Interface Characteristics

100GBASE-LX4 Operation (EOL, TOP = 0 ~70 °C ,VCC = 3.135 to 3.465 V)

Parameter	Symbol	Min	Typical	Max	Unit	Note
Power Dissipation				3.5	W	
Supply Current	Icc			1	A	
Transmitter						
Data Rate, each lane			25.78125		Gbps	
Differential Voltage pk-pk	Vpp	300		850	mV	
Input differential impedance	Rin		100		Ohm	1
Differential Termination Resistance Mismatch				10	%	
Receiver						
Data Rate, each lane			25.78125		Gbps	
Output differential impedance	Rout		100		Ohm	1
Differential Termination Resistance Mismatch				10	%	
Differential output voltage	Vout, pp	260		850	mV	2

Notes:

- 1.Connected directly to TX data input pins. AC coupled thereafter.
- 2.Into 100Ωdifferential termination.

V. Digital Diagnostic Monitoring Functions

LQP100-LX4 support the I2C-based Diagnostic Monitoring Interface (DMI) defined in document SFF-8636. The host can access real-time performance of transmitter and receiver optical power, temperature, supply voltage and bias current.

Parameter	Accuracy	Unit
Case Temperature	±3	°C
Supply Voltage	±3%	V
Tx Bias Current	±10%	mA
Tx Optical Power	±3	dB
Rx Optical Power	±3	dB

VI. Block Diagram

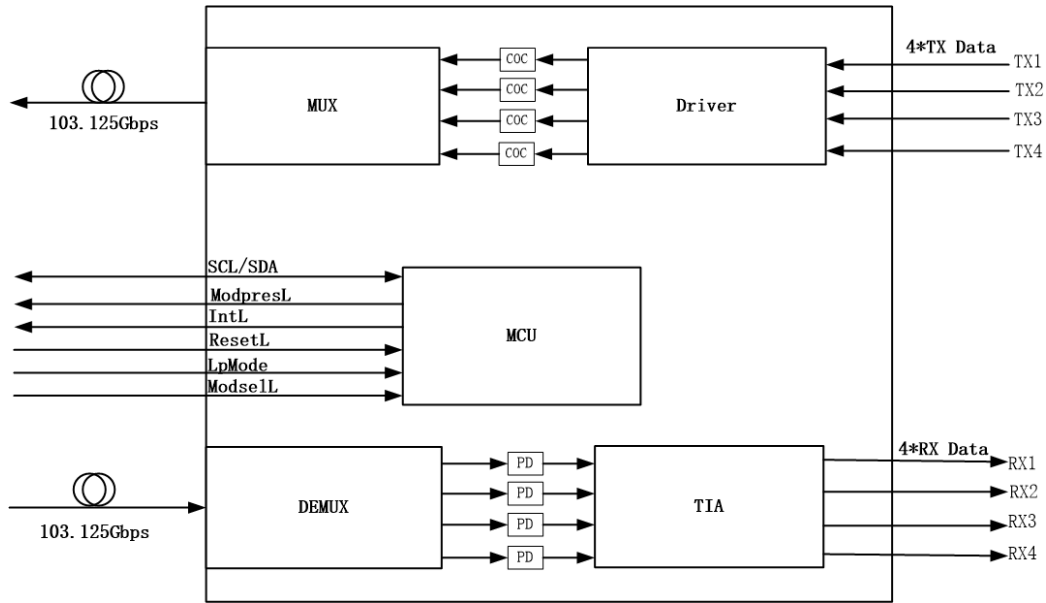

VII. Pin Diagram

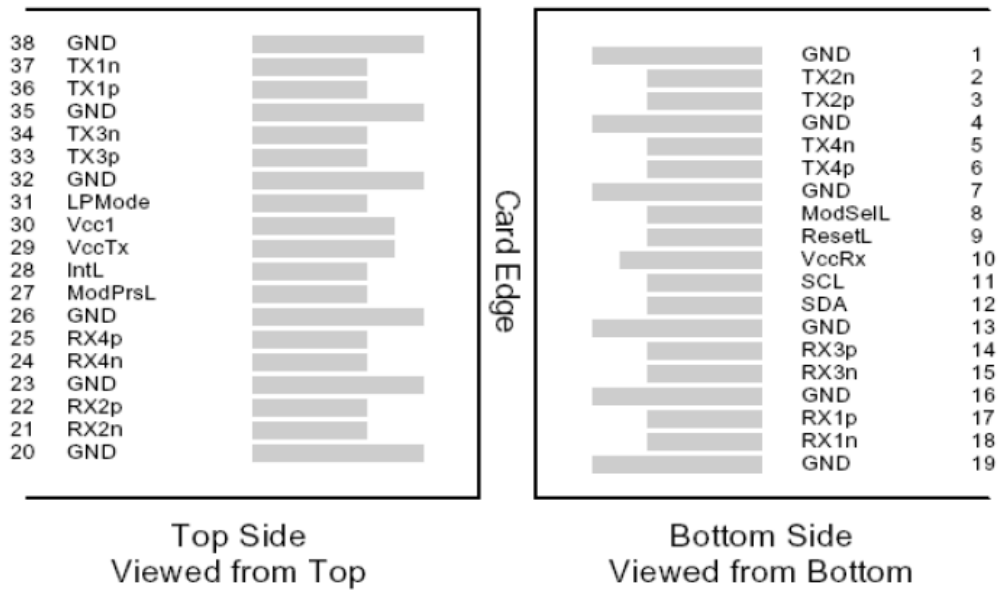

QSFP28 38pin connector (SFF 8665)

VIII. Pin Descriptions

Pin	Symbol	Name/Description	Note
1	GND	Ground	1
2	Tx2n	Transmitter Inverted Data Input	
3	Tx2p	Transmitter Non-Inverted Data Input	
4	GND	Ground	1

5	Tx4n	Transmitter Inverted Data Input	
6	Tx4p	Transmitter Non-Inverted Data Input	
7	GND	Ground	1
8	ModSelL	Module Select	
9	ResetL	Module Reset	
10	Vcc Rx	+3.3V Power supply receiver	
11	SCL	2-wire serial interface clock	
12	SDA	2-wire serial interface data	
13	GND	Ground	1
14	Rx3p	Receiver Non-Inverted Data Output	
15	Rx3n	Receiver Inverted Data Output	
16	GND	Ground	1
17	Rx1p	Receiver Non-Inverted Data Output	
18	Rx1n	Receiver Inverted Data Output	
19	GND	Ground	1
20	GND	Ground	1
21	Rx2n	Receiver Inverted Data Output	
22	Rx2p	Receiver Non-Inverted Data Output	
23	GND	Ground	1
24	Rx4n	Receiver Inverted Data Output	
25	Rx4p	Receiver Non-Inverted Data Output	
26	GND	Ground	1
27	ModPrSL	Module Present	
28	IntL	Interrupt	
29	Vcc Tx	+3.3V Power supply transmitter	
30	Vcc1	+3.3V Power supply	
31	LPMode	Low Power Mode	
32	GND	Ground	1
33	Tx3p	Transmitter Non-Inverted Data Input	
34	Tx3n	Transmitter Inverted Data Input	
35	GND	Ground	1
36	Tx1p	Transmitter Non-Inverted Data Input	
37	Tx1n	Transmitter Inverted Data Input	
38	GND	Ground	1

Note :

1. Circuit ground is internally isolated from chassis ground.

IX. Mechanical Specifications(Unit: mm)

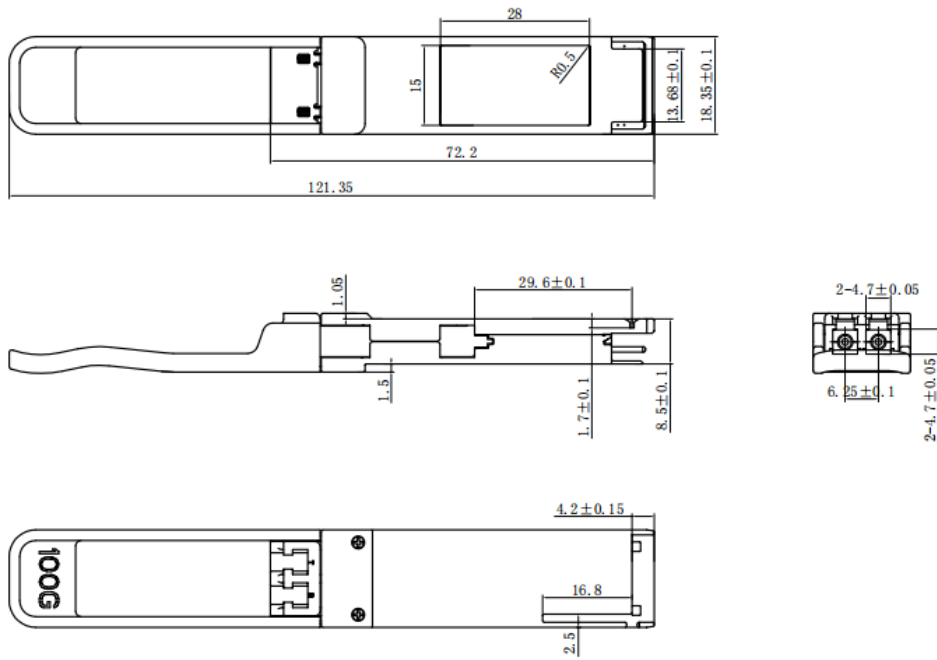

Revision History

Version No.	Date	Description
1.0	June 24, 2021	Preliminary datasheet