

# LQP100-PSM4-02

## QSFP28 100Gb/s PSM4 2km DDM Transceiver

### PRODUCT FEATURES

- MPO-12 optical interface
- Maximum link length up to 2km
- Up to 25.78125Gb/s data links per lane
- +3.3 V power supply
- QSFP MSA compliant package
- Hot Pluggable
- High performance single mode DML transmitter
- High sensitivity PIN/TIA optical receiver
- Single Mode operation
- BER < 5E-5@-12.1
- Built-in CDR
- Case Operating temperature : 0 to 70°C
- Data and Control Interfaces
- Tx Data CML/AC Coupled
- Rx Data CML/AC Coupled
- ModSelL LVTTTL
- ResetL LVTTTL
- ModPrsL LVTTTL
- LPMode LVTTTL
- 2-wire I2C communication bus
- RoHS 6 compliance

## APPLICATIONS

- 100G BASE Ethernet
- Infiniband EDR interconnects
- Enterprise networking

## Product Description

The LQP100-PSM4-02 QSFP28 optical transceiver is intended for up to 2km reach service with four-lane 25.78125G data rate. It is based on 3.3V DC power supply and operates in the commercial temperature range. It is compliant with QSFP MSA 、SFF-8436 、SFF-8636 and PSM4 MSA. Digital diagnostic functions are available via I2C interface, and the control functions can be achieved by LVTTTL interfaces on the host , mainly including Module Select(ModSelL)、Module Reset(ResetL)、 Low Power Mode(LPMode). The transceiver incorporates a four-laser array which is usually DFB 、four-PIN diode array 、 a high performance CDR integrated four drivers and TIAs IC separately. The differential AC coupled Tx and Rx data interfaces are CML compatible. The device can operate in Class IV safely.

## Ordering Information

Part No.	Case Operating Temperature
LQP100-PSM4-02	0 to 70 °C

## I. Absolute Maximum Ratings

Parameter	Symbol	Min	Max	Units	Notes
Storage Temperature	T <sub>stg</sub>	-40	+95	°C	
Case Operating Temperature (Commercial )	T <sub>O</sub>	0	+70	°C	
Relative Humidity - Storage	RH <sub>s</sub>	0	95	%	
Relative Humidity - Operating	RH <sub>o</sub>	0	85	%	
Supply Voltage	V <sub>cc</sub>	-0.3	3.6	V	

## II. Operating conditions

Parameter	Symbol	Min	Typ	Max	Units	Notes
Case Operating Temperature	T <sub>case</sub>	0	-	+70	°C	
DC Supply Voltage	V <sub>cc</sub>	3.135	-	3.465	V	
Module Supply Current	I <sub>IN</sub>	-	-	1000	mA	

### III. Electrical Characteristics

Parameter	Symbol	Mi	Typ	Max	Units	Notes
<b>Transmitter</b>						
Differential Data input Swing	VIN	180	-	900	mV	
Tx Differential Input Impedence	Zin	90	100	110	$\Omega$	
Tx Differential Output Impedence	Zout	45	50	55	$\Omega$	
ResetL Disable Voltage	Vr	2.0	-	Vcc+0.3	V	
ResetL Enable Voltage	VrEN	0	-	0.8	V	
ModSelL Disable Voltage	Vm	2.0	-	Vcc+0.3	V	
ModSelL Enable Voltage	VmEN	0	-	0.8	V	
<b>Receiver</b>						
Differential Data Output Swing	VOUT	180	-	900	mV	
Rx Differential Output Impedence	ZOUT	90	100	110	$\Omega$	
IntL Assert Voltage	VInt	Vcc-0.5	-	VCC+0.3	V	
IntL De-assert Voltage	VDInt	0	-	+0.4	V	

### IV. Optical Specification

Parameter	Symbol	Min	Typ	Max	Units	Notes
<b>Transmitter</b>						
Signal Rate Each Lane			25.78125±100ppm		Gbps	
Lane Wavelength	L0	1295	1310	1325	nm	
	L1	1295	1310	1325	nm	
	L2	1295	1310	1325	nm	
	L3	1295	1310	1325	nm	
Side Mode Suppression Ratio	SMSR	30			dB	
Average Launch Power Each Lane	Pavg	-9.4		2.0	dBm	
Optical Modulation Amplitude Each Lane	OMA			2.2	dBm	1
Transmitter and dispersion penalty Each Lane	TDP			2.9	dB	
Eye Mask coordinates: X1, X2, X3, Y1, Y2, Y3		{0.31, 0.4, 0.45, 0.34, 0.38, 0.4}				2
Average launch power of OFF transmitter Each Lane				-30	dBm	
Extinction Ratio	ER	3.5			dB	
Spectral Width 20dB				1	nm	
Transmitter Reflectance				-12	dB	
Optical return loss tolerance				20	dB	

Receiver						
Signal Speed Per Lane			25.78125±100ppm		Gbps	
Lane Wavelength	L0	1295	1310	1325	nm	
	L1	1295	1310	1325	nm	
	L2	1295	1310	1325	nm	
	L3	1295	1310	1325	nm	
Damage threshold  <sub>Each Lane</sub>	THd			3.0	dBm	3
Average Receive Power  <sub>Each Lane</sub>		-12.66		2.0	dBm	
Receiver reflectance				-26	dB	
Sensitivity OMA  <sub>Each Lane</sub> [1]	Sen			-12.1	dBm	4
Stressed Receiver Sensitivity (OMA), each Lane				-8.8	dBm	
LOS Assert	LOSA		-18			
LOS Deassert	LOSD		-16			
LOS Hysteresis	LOSH	0.5		3		
Vertical Eye Closure Penalty	VECP	1.9			dB	5
Stressed Eye J2 Jitter	J2		0.27		UI	
Stressed Eye J4 Jitter	J4		0.39		UI	

Notes:

1. Even if the TDP < 1 dB, the OMA min must exceed the minimum value specified here.
2. Hit ratio of 5e-5, per IEEE.
3. The receiver shall be able to tolerate, without damage, continuous exposure to a modulated optical input signal having this power level on one lane. The receiver does not have to operate correctly at this input power.
4. Measured with conformance test signal at receiver input for BER = 5e-5 BER.
5. Vertical eye closure penalty and stressed eye jitter are test conditions for measuring stressed receiver sensitivity. They are not characteristics of the receiver

## V. Digital Diagnostics

Parameter	Symbol	Spec	Units	Condition/Notes
Temperature	Te	+/-3	°C	
Voltage	Vcc	+/-5%	V	
IBias	BIAS	+/-10%	mA	
Rx power	Rx-pwr	+/-2	dBm	
Tx power	Tx-pwr	+/-2	dBm	

## VI. PIN Assignmen

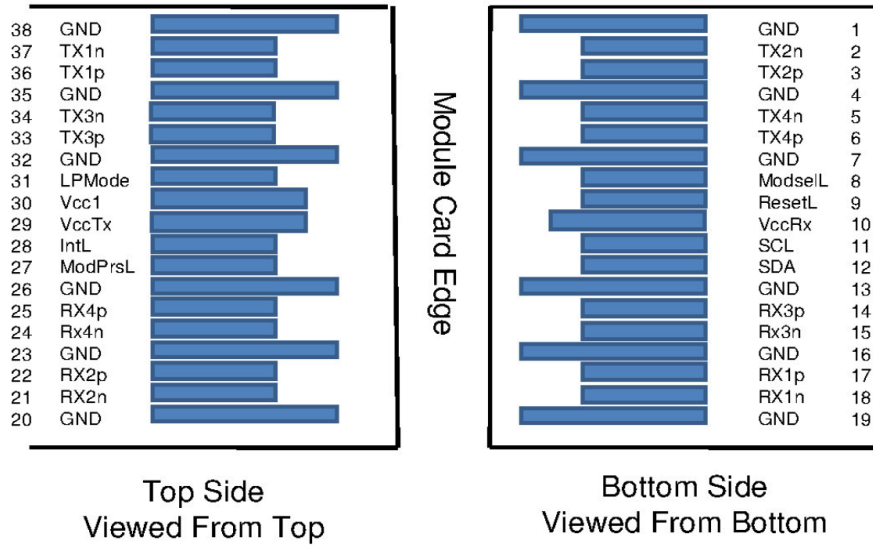

## VII. Pin Definitions

PIN	Symbol	Name/Description	Note
1	GND	Ground	1
2	Tx2n	Transmitter Inverted Data Input	
3	Tx2p	Transmitter Non-Inverted Data output	
4	GND	Ground	1
5	Tx4n	Transmitter Inverted Data Input	
6	Tx4p	Transmitter Non-Inverted Data output	
7	GND	Ground	1
8	ModSelL	Module Select	
9	ResetL	Module Reset	
10	VccRx	+3.3V Power Supply Receiver	2
11	SCL	2-Wire Serial Interface Clock	
12	SDA	2-Wire Serial Interface Data	
13	GND	Ground	1
14	Rx3p	Receiver Non-Inverted Data Output	
15	Rx3n	Receiver Inverted Data Output	
16	GND	Ground	1
17	Rx1p	Receiver Non-Inverted Data Output	
18	Rx1n	Receiver Inverted Data Output	
19	GND	Ground	1
20	GND	Ground	1
21	Rx2n	Receiver Inverted Data Output	
22	Rx2p	Receiver Non-Inverted Data Output	
23	GND	Ground	1

24	Rx4n	Receiver Inverted Data Output	
25	Rx4p	Receiver Non-Inverted Data Output	
26	GND	Ground	1
27	ModPrsL	Module Present	
28	IntL	Interrupt	
29	VccTx	+3.3 V Power Supply transmitter	2
30	Vcc1	+3.3 V Power Supply	2
31	LPMode	Low Power Mode	
32	GND	Ground	1
33	Tx3p	Transmitter Non-Inverted Data output	
34	Tx3n	Transmitter Inverted Data Input	
35	GND	Ground	1
36	Tx1p	Transmitter Non-Inverted Data output	
37	Tx1n	Transmitter Inverted Data Input	
38	GND	Ground	1

## Notes:

- GND is the symbol for signal and supply (power) common for the QSFP module. All are common within the QSFP+ module and all module voltages are referenced to this potential unless otherwise noted. Connect these directly to the host board signal-common ground plane.
- Vcc Rx, Vcc1 and Vcc Tx are the receiver and transmitter power supplies and shall be applied concurrently. Requirements defined for the host side of the Host Edge Card Connector are listed . Recommended host board power supply filtering is shown in Figures 3 and 4. Vcc Rx Vcc1 and Vcc Tx may be internally connected within the QSFP+ Module in any combination. The connector pins are each rated for a maximum current of 500 mA

## VIII. Electrical Interface

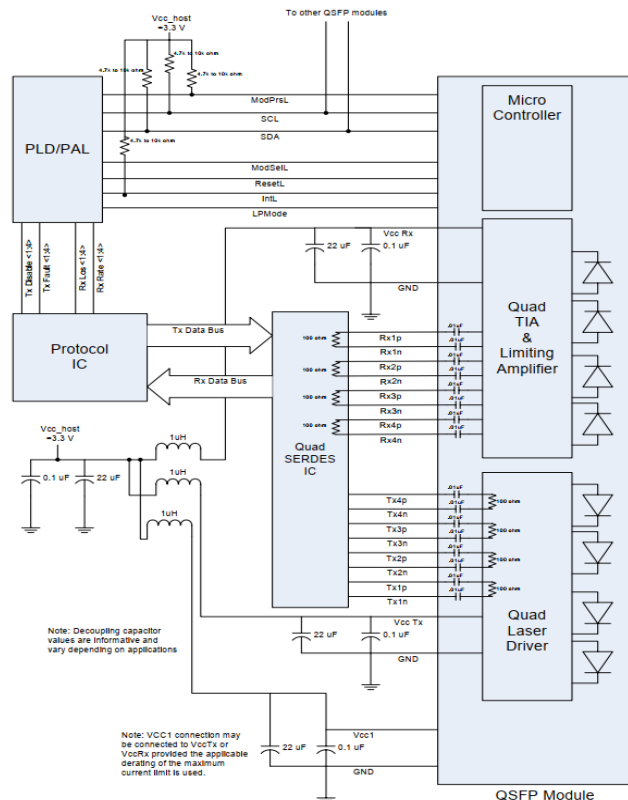

**Recommended PCB Layout**

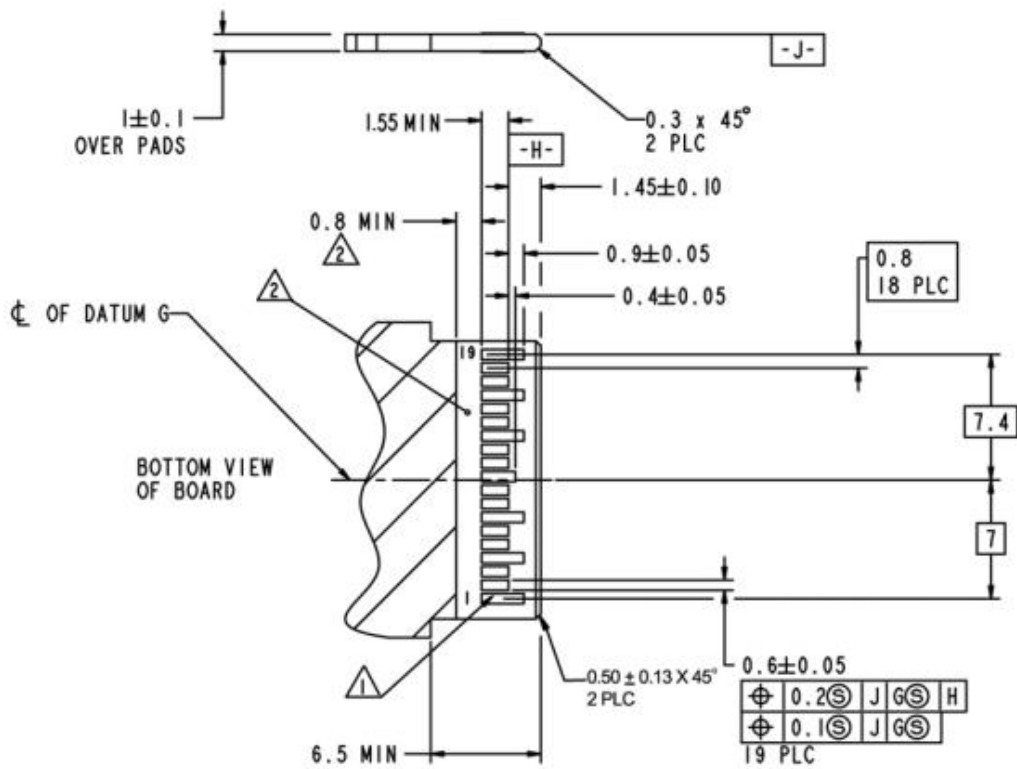
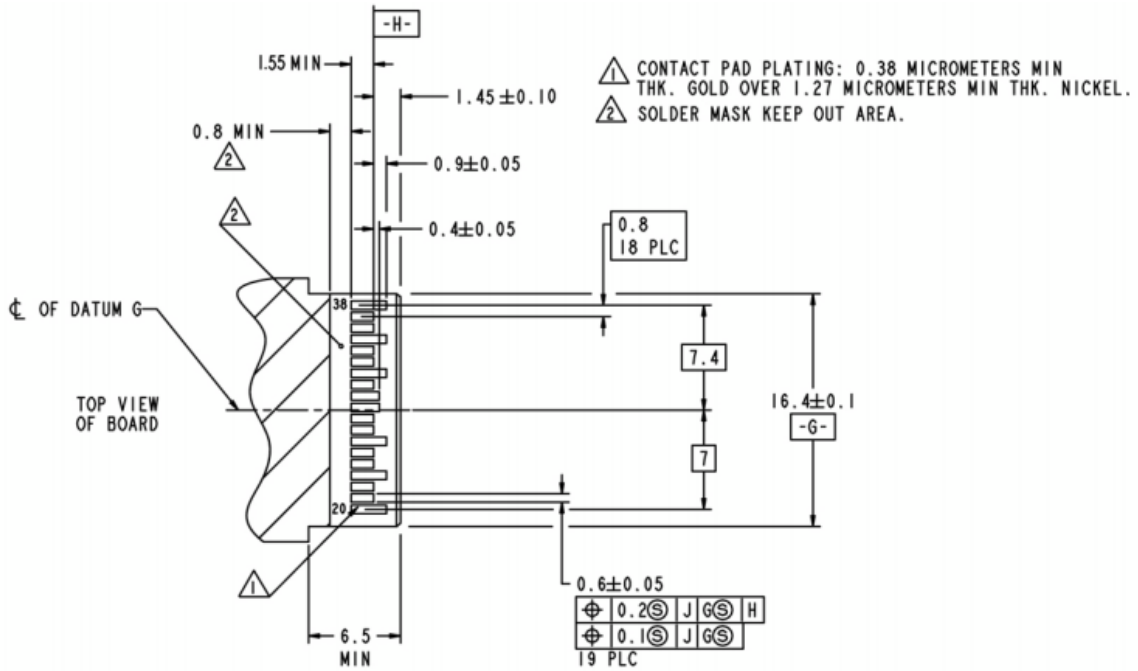

## IX. Mechanical Diagram

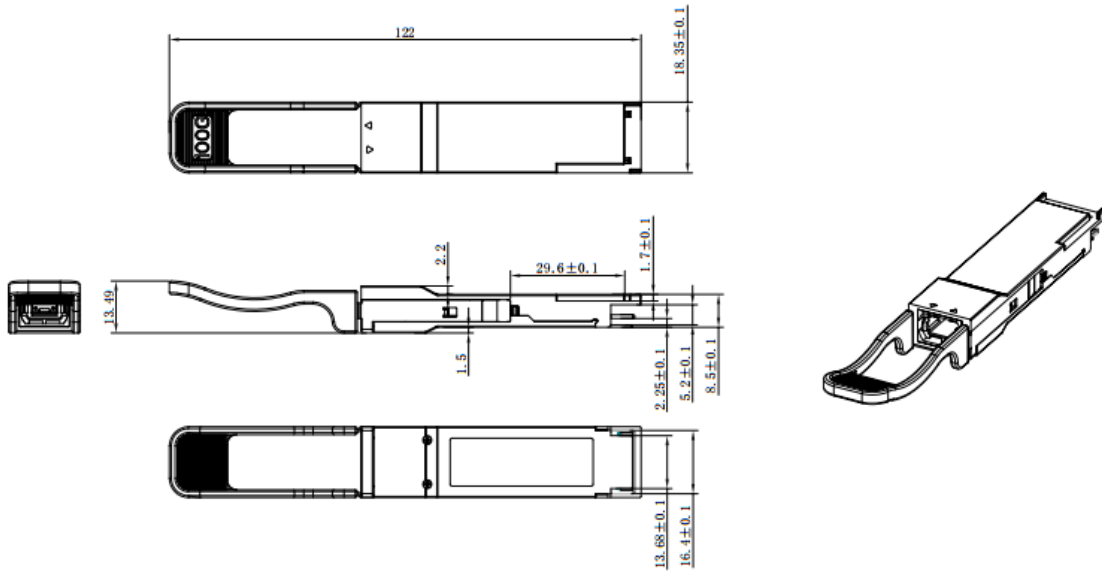

Notes:

- 1、Tolerance: +/-0.1mm.
- 2、Others according to SFF-8661 or customer spec .
- 3、Optical port according to fiber connector spec.

## Revision History

Version No.	Date	Description
1.0	June 24, 2020	Preliminary datasheet