

LQP100-AOC-xxx

100G QSFP28 Active Optical Cable

PRODUCT FEATURES

- Support 100GBASE-SR4/EDR application
- Compliant to QSFP28 Electrical MSA SFF-8636
- Multi rate of up to 25.78125Gbps
- +3.3V single power supply
- Low power consumption
- Operating case temp
Commercial: 0°C to +70 °C
- RoHS compliant

APPLICATIONS

- 100GBASE-SR4 at 25.78125Gbps per lane
- InfiniBand QDR, EDR
- Other optical links

Ordering information

Part Number	Product Description	Fiber Spec.
LQP100-AOC-001	100G QSFP28 Active Optical Cable 1Meter	OM4
LQP100-AOC-003	100G QSFP28 Active Optical Cable 3Meters	OM4
LQP100-AOC-005	100G QSFP28 Active Optical Cable 5Meters	OM4
LQP100-AOC-007	100G QSFP28 Active Optical Cable 7Meters	OM4
LQP100-AOC-010	100G QSFP28 Active Optical Cable 10Meters	OM4
LQP100-AOC-015	100G QSFP28 Active Optical Cable 15Meters	OM4
LQP100-AOC-020	100G QSFP28 Active Optical Cable 20Meters	OM4
LQP100-AOC-025	100G QSFP28 Active Optical Cable 25Meters	OM4
LQP100-AOC-030	100G QSFP28 Active Optical Cable 30Meters	OM4
LQP100-AOC-050	100G QSFP28 Active Optical Cable 50Meters	OM4
LQP100-AOC-100	100G QSFP28 Active Optical Cable 100Meters	OM4

I. Absolute Maximum Ratings

Parameter	Symbol	Min.	Typical	Max.	Unit	Notes
Supply Voltage	V _{CC3}	-0.5	-	+3.6	V	
Storage Temperature	T _s	-5	-	+75	°C	
Operating Humidity	RH	+5	-	+85	%	1

Note1: No condensation.

II. Recommended Operating Conditions

Parameter	Symbol	Min.	Typical	Max.	Unit	Notes
Operating Case Temperature	T _c	0	-	+70	°C	
Power Supply Voltage	V _{CC}	3.14	3.3	3.47	V	
Power Dissipation	P _d	-	-	2.5	W	1
Bit Rate	BR	10.3125	25.78125	-	Gbps	

Note1: Per terminal.

III. Electrical Characteristics

Parameter	Symbol	Min.	Typ.	Max.	Units	Notes
Transmitter						
Differential Data Input Swing	V _{out}	200	-	1000	mV	
Input Differential Impedance	Z _D	90	100	110	Ω	
ModSelL	Module Select	V _{OL}	V _{EE} -0.3	-	0.4	V
	Module Unselect	V _{OH}	2.0	-	V _{CC} +0.3	V
LPMMode	Low Power Mode	V _{IL}	V _{EE} -0.3	-	0.8	V

	Normal Operation	V_{IH}	2.0	-	$V_{CC}+0.3$	V	
ResetL	Reset	V_{IL}	$V_{EE}-0.3$	-	0.8	V	
	Normal Operation	V_{IH}	2.0	-	$V_{CC}+0.3$	V	
Receiver							
Differential Data Output Swing		$V_{in,P-P}$	200	-	1000	mV _{PP}	
Output Differential Impedance		Z_D	90	100	110	Ω	
ModPrsL	Normal Operation	V_{OL}	$V_{EE}-0.3$	-	0.4	V	
IntL	Interrupt	V_{OL}	$V_{EE}-0.3$	-	0.4	V	
	Normal Operation	V_{OH}	2.0	-	$V_{CC}+0.3$	V	
Bit Error Rate		BER			E-12		1

Note: 1 PRBS2^31-1@25.78125Gbps

IV. Recommended Interface Circuit

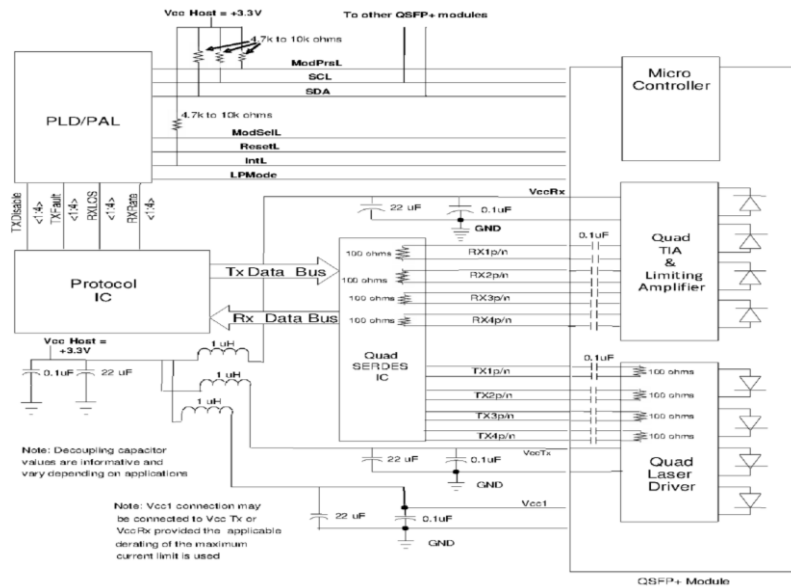

V. Pin arrangement

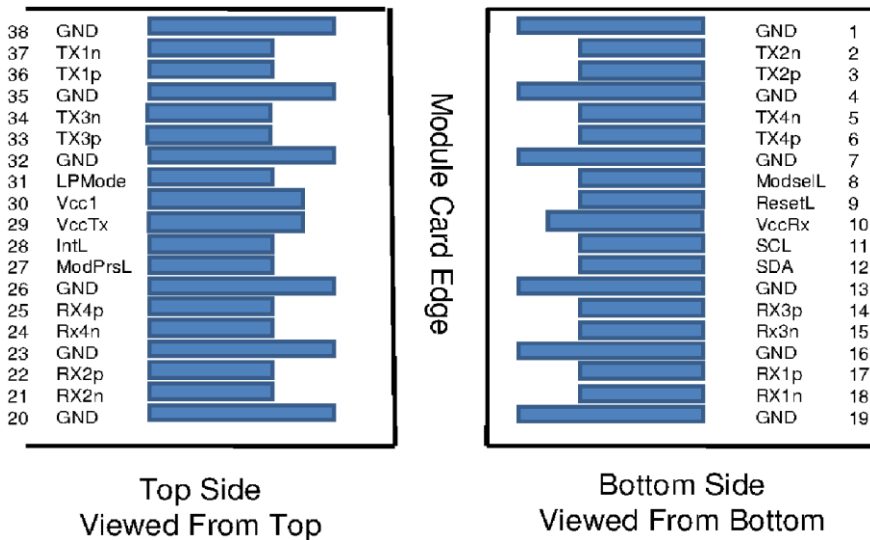

VI. Pin Function Definitions

Pin	Symbol	Name/Description	Notes
1	GND	Ground	1
2	Tx2n	Transmitter Inverted Data Input	
3	Tx2p	Transmitter Non-Inverted Data Input	
4	GND	Ground	1
5	Tx4n	Transmitter Inverted Data Input	
6	Tx4p	Transmitter Non-Inverted Data Input	
7	GND	Ground	1
8	ModSelL	Module Select	
9	ResetL	Module Reset	
10	Vcc Rx	+3.3V Power Supply Receiver	
11	SCL	2-wire serial interface clock	
12	SDA	2-wire serial interface data	
13	GND	Ground	1
14	Rx3p	Receiver Non-Inverted Data Output	
15	Rx3n	Receiver Inverted Data Output	
16	GND	Ground	1
17	Rx1p	Receiver Non-Inverted Data Output	
18	Rx1n	Receiver Inverted Data Output	
19	GND	Ground	1
20	GND	Ground	1
21	Rx2n	Receiver Inverted Data Output	
22	Rx2p	Receiver Non-Inverted Data Output	
23	GND	Ground	1
24	Rx4n	Receiver Inverted Data Output	
25	Rx4p	Receiver Non-Inverted Data Output	
26	GND	Ground	1
27	ModPrsL	Module Present	
28	IntL	Interrupt	
29	Vcc Tx	+3.3V Power supply transmitter	
30	Vcc1	+3.3V Power supply	
31	LPMODE	Low Power Mode	
32	GND	Ground	1
33	Tx3p	Transmitter Non-Inverted Data Input	
34	Tx3n	Transmitter Inverted Data Input	
35	GND	Ground	1
36	Tx1p	Transmitter Non-Inverted Data Input	
37	Tx1n	Transmitter Inverted Data Input	
38	GND	Ground	1

Note: 1. Circuit ground is internally isolated from chassis ground.

VII. Monitoring Specification

2-Wire Serial Address 1010000x	
Lower Page 00h	
0	Identifier
1- 2	Status
3- 21	Interrupt Flags
22- 33	Free Side Device Monitors
34- 81	Channel Monitors
82- 85	Reserved
86- 98	Control
99	Reserved
100-104	Hardware Interrupt Pin Masks
105-106	Vendor Specific
107	Reserved
108-110	Free Side Device Properties
111-112	Assigned for use by PCI Express
113	Free Side Device Properties
114-118	Reserved
119-122	Password Change Entry Area (Optional)
123-126	Password Entry Area (Optional)
127	Page Select Byte

Upper Page 00h	Optional Page 01h	Optional Page 02h	Optional Page 03h
128 Identifier	128 CC_APPS	128-255 User EEPROM Data	128-175 Free Side Device Thresholds
129-191 Base ID Fields	129 AST Table Length (TL)		
	130-131 Application Code Entry 0		
	132-133 Application Code Entry 1		
192-223 Extended ID	134-253 other entries	176-223 Channel Thresholds	
224-255 Vendor Specific ID	254-255 Application Code Entry TL	224 Tx EQ & Rx Emphasis Magnitude ID	225 RX output amplitude indicators
		226-241 Channel Controls	242-251 Channel Monitor Masks
		252-255 Reserved	

VIII. Mechanical Drawing

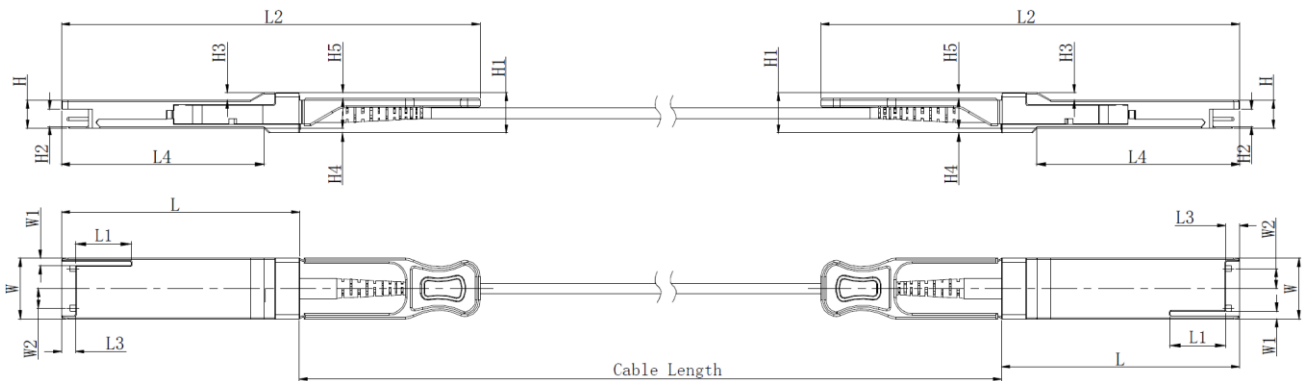

	L	L1	L2	L3	L4	W	W1	W2	H	H1	H2	H3	H4	H5
Max	72.2	-	128	4.35	61.4	18.45	-	6.2	8.6	12.4	5.35	2.5	1.6	2.0
Type	72.0	-	-	4.20	61.2	18.35	-	-	8.5	12.2	5.2	2.3	1.5	1.8
Min	68.8	16.5	124	4.05	61.0	18.25	2.2	5.8	8.4	12.0	5.05	2.1	1.3	1.6

Revision History

Version No.	Date	Description
1.0	June 24, 2021	Preliminary datasheet