

LXP-M85-02DI

SFP+ 10Gb/s 850nm Multi-mode 300m DDM

PRODUCT FEATURES

- Compliant to SFP+ MSA
- Fully RoHS Compliant
- All metal housing for superior EMI performance
- Data rate from 8.5Gbps to 10Gbps
- VCSEL 850nm Laser
- High sensitivity PIN photodiode and TIA
- Up to 300m
- LC duplex connector
- Hot pluggable 20pin connector
- Low power consumption < 1.0W
- -40°C to 85°C operating wide temperature range
- Single +3.3V ±5% power supply
- Digital Diagnostic Monitoring sff-8472 Rev10.2 compliant
- Real time monitoring of :
 - Transmitted optical power
 - Received optical power
 - Laser bias current
 - Temperature
 - Supply voltage

APPLICATIONS

- 10GBASE -SR
- 8.5G/10.5G/s Fiber Channel

Compliance

- IEEE 802.3ae 10GBASE –SR
- SFF-8431 Rev 3.0
- SFF-8472 Rev 10.2
- FC-PI-4 Rev 7.0

PRODUCT DESCRIPTION

The LXP-M85-02DI 850nm 10Gigabit Transceiver is designed to transmitter and receive serial optical data over multi mode optical fiber with 300m.

They are compliant with SFF-8431, SFF-8472, FC-P1-4 Rev7.0 and IEEE802.3ae 10GBASE-SR.

The transmitter converts serial CML electrical data into serial optical data compliant with the IEEE802.3ae standard. An open collector compatible Transmit Disable (Tx_Dis) is provided. When Tx_Dis is asserted high, Transmitter is turned off.

The receiver converts serial optical data into serial CML electrical data. An open collector compatible loss of signal is provided. The RX_LOS signal indicates insufficient optical power for reliable signal reception at the receiver. Digital diagnostics functions are available via 2-wire serial interface, as specified in sff-8472.

The optical output can be disabled by a TTL logic high-level input of Tx Disable, and the system also can disable the module via I2C. Tx Fault is provided to indicate that degradation of the laser. Loss of signal (LOS) output is provided to indicate the loss of an input optical signal of receiver or the link status with partner. The system can also get the LOS (or Link)/Disable/Fault information via I2C register access.

Ordering information

Part No	package	Data rate	Tx	Optical Power	Rx	Top	Reach	other
LXP-M85-02DI	SFP+	10Gbps	850nm	-7.3~-1dBm	PIN	-40~85 °C	300m	DDM

I. Absolute Maximum Ratings

Parameter	Symbol	Min.	Typ.	Max.	Unit	Ref.
Storage Temperature	T _s	-40		85	°C	
Storage Ambient Humidity	H _A	5		95	%	

II. Recommended Operating Conditions

Parameter	Symbol	Min.	Typ.	Max.	Unit	Note	
Case Operating Temperature	T _{case}	-40		85	°C		
Ambient Humidity	H _A	5		70	%	Non-condensing	
Power Supply Voltage	V _{cc}	3.13	3.3	3.47	V		
Bit Rate	BR	8.5	10.3	10.5	Gb/s		
Bit Error Ratio	BER				10-12		
Max Supported link Length							
Coupled Fiber		Multi mode fiber					50/125um MMF

III. Electrical Characteristics (T_c = -40°C to 85°C and V_{cc} = 3.14 to 3.46)

Parameter	Symbol	Min.	Typ.	Max.	Unit	Note
Supply Voltage	V _{cc}	3.14	3.3	3.46	V	
Supply Current	I _{cc}			300	mA	

Transmitter						
Input Differential Impedance	Rin	80	100	120	Ω	
Differential Data Input Swing	Vin	100		1000	mVp-p	
Transmit Disable Voltage	Vdis	2			V	
Transmit Enable Voltage	Ven	Vee		Vee+0.8	V	
Transmit Fault Assert Voltage	Vfa	2.2			V	
Transmit Fault De-Assert Voltage	Vfda	Vee		Vee+0.4	V	
Receiver						
Differential Data Output Swing	Vod	300	600	840	mVp-p	
Output Rise Time	Trise		25		ps	20%~80%
Output Fall Time	Tfall		25		ps	20%~80%
LOS Fault	Vlosft	2		Vcc	V	
LOS Normal	Vlosnr	Vee		Vee+0.8	V	

IV. Optical Characteristics(Tc =-40℃ to 85 ℃ and Vcc= 3.14V to 3.46V)

Parameter	Symbol	Min.	Typ.	Max.	Unit	Note
Transmitter						
Nominal Wavelength	λ	840	850	860	nm	
Spectral width	$\Delta\lambda$			0.85	nm	
Optical Modulation Amplitude	Poma	-5.4			dBm	
Optical Output Power	Pav	-7.3		-1	dBm	
Extinction Ratio	ER	3.5			dB	
Transmitter and Dispersion Penalty	TDP			3.9	dB	
Launch Power in OMA Minus TDP		-6.2			dBm	
Average Launch Power of OFF Transmitter	Poff			-35	dBm	
Relative Intensity Noise	Rin			-128	dB/HZ	
Optical Return Loss Tolerance	ORLT			12	dB	
Receiver						
Center Wavelength	λ	840	850	860	nm	
Average Receiver Power	Pavg			-9.9	dBm	1
Receiver Optial Return Loss	ORL	12			dB	
Receiver Saturation	Rsat	0			dBm	
Los Assert LOS	LOSd	-30			dBm	
Los De-Assert LOS	LOSa			-12	dBm	
Los Hysteresis		0.5			dB	

Note: Sensitivity for 10.3G PRBS 2*23-1 and BER better than or equal to 10E-12.

V. Pin Diagram

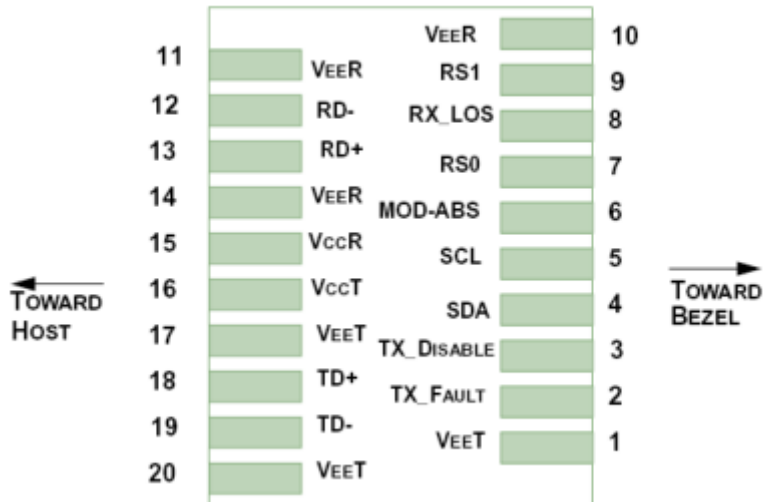

VI. Pin Descriptions

Pin	Symbol	Name	Description
1,17,20	VeeT	Transmitter Signal Ground	These pins should be connected to signal ground on the host board.
2	TX Fault	Transmitter Fault Out (OC)	Logic“1”Output=Laser Fault(Laser off before t_fault) Logic“0”Output=Normal Operation This pin is open collector compatible,and should be pulled up to Host Vcc with a 10kΩ resistor
3	TX Disable	Transmitter Disable In (LVTTTL)	Logic “1”Input(or no connection)=laser off Logic “0”Input = Laser on This pin is internally pulled up to VccT with a 10kΩ resistor
4	SDA	Module Definition Identifiers	Serial ID with SFF-8472 Diagnostics Module Definition pins should be pulled up to Host Vcc with 10 kΩ resistors.
5	SCL		
6	MOD-ABS		
7	RS0	ReceiverRateSelect(LVTTTL)	These pins have an internal 30 kΩ pull-down to ground. A Signal on either of these pins will not affect module performance.
9	RS1	Transmitter Rate Select(LVTTTL)	
8	LOS	Loss of signal Out(OC)	Sufficient optical signal for potential BER<1x10 ⁻¹² =Logic “0” Insufficient optical signal for potential BER<1x10 ⁻¹² =Logic “1” This pin is open collector compatible ,and should be pulled up to Host Vcc with a 10 kΩ resistor
10,11,14	VeeR	Receiver Signal Ground	This pins should be connected to signal ground on the host board.
12	RD-	Receiver Negative Data	Light on = Logic “0”Output Receiver Data output is internally

		Out(CML)	AC coupled and series terminated with a 50Ω resistor.
13	RD+	Receiver Positive Data Out(CML)	Light on = Logic “1” Output Receiver Data output is internally AC coupled and series terminated with a 50Ω resistor.
15	VccR	Receiver Power Supply	This pin should be connected to a filtered +3.3V power supply on the host board .See Figure3.Recommended power supply filter
16	VccT	Transmitter Power Supply	This pin should be connected to a filtered +3.3V power supply on the host board .See Figure3.Recommended power supply filter

VII. Typical application circuit

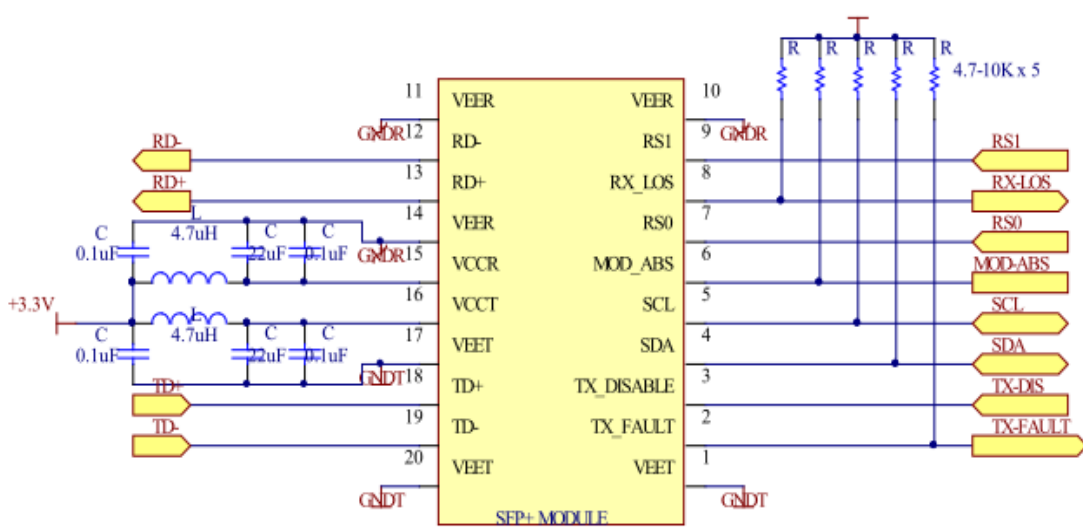

VIII. Digital Diagnostic Interface Definition

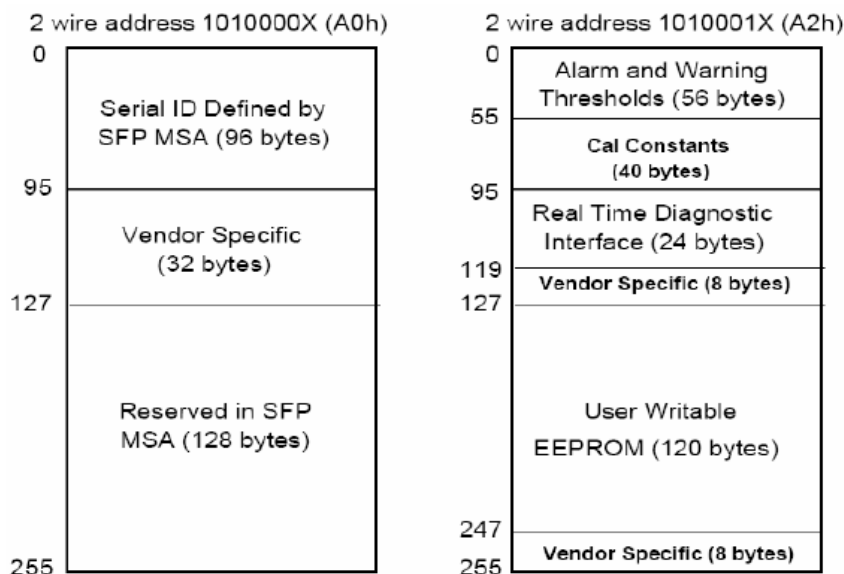

IX. Mechanical Specifications(Unit: mm)

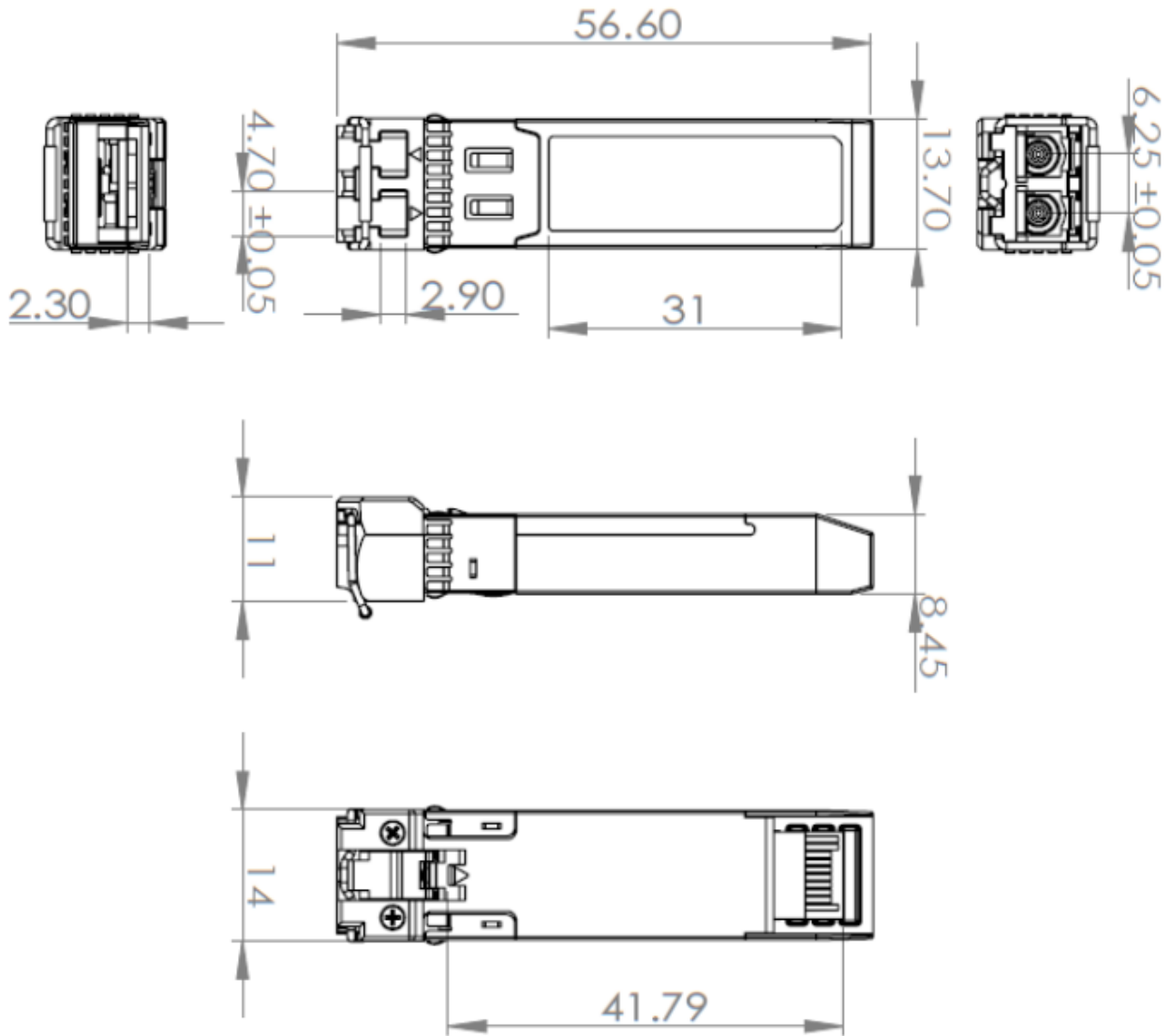

Revision History

Version No.	Date	Description
1.0	June 24, 2020	Preliminary datasheet