

LGP-M85-02DI

SFP 1.25Gb/s 850nm Multi-mode 550m DDM

PRODUCT FEATURES

- Up to 1.25Gbps data rate
- 850nm VCSEL laser transmitter
- Pin photo-detector
- Up to 0.55km on 50/125um MMF
- Hot- pluggable SFP footprint
- LC pluggable optical interface
- Low power dissipation
- Metal enclosure, for lower EMI
- Single +3.3V power supply
- Support Digital Diagnostic Monitoring interface
- Compliant with SFF-8472
- Case operating temperature -40 °C to 85 °C

APPLICATIONS

- Gigabit Ethernet
- Gigabit Fiber Channel
- Other optical link

Compliance

- SFP MSA
- SFF-8472
- IEEE802.3z
- RoHS

PRODUCT DESCRIPTION

The LGP-M85-02DI Small Form Factor Pluggable (SFP) transceivers are compatible with the Small Form Factor Pluggable Multi-Sourcing Agreement (MSA). The transceiver consists of five sections: the LD driver, the limiting amplifier, the digital diagnostic monitor, the 850nm VCSEL laser and the PIN photo-detector. The module data link up to 0.55KM in 50/125um multi mode fiber.

The optical output can be disabled by a TTL logic high-level input of Tx Disable, and the system also can disable the module via I2C. Tx Fault is provided to indicate that degradation of the laser. Loss of signal (LOS) output is provided to indicate the loss of an input optical signal of receiver or the link status with partner. The system can also get the LOS (or Link)/Disable/Fault information via I2C register access.

Ordering information

Package	Part NO.	Data Rate	TX	RX	Interface	Reach (km)	Temp
SFP	LGP-M85-02DI	1.25Gb/s	850 VCSEL	PIN	LC	0.55	-40~85 °C

I. Absolute Maximum Ratings

Parameter	Symbol	Min.	Typ.	Max.	Unit	Note
Storage Temperature	Ts	-40		85	°C	
Storage Ambient Humidity	HA	5		95	%	
Power Supply Voltage	Vcc	-0.5		4	V	
Signal Input Voltage		-0.3		Vcc+0.3	V	
Receiver Damage Threshold		5			dBm	

II. Recommended Operating Conditions

Parameter	Symbol	Min.	Typ.	Max.	Unit	Note
Case Operating Temperature	Tcase	-40		85	°C	
Ambient Humidity	HA	5		70	%	Non-condensing
Power Supply Voltage	Vcc	3.13	3.3	3.47	V	
Power Supply Current	ICC			280	mA	
Power Supply Noise Rejection				100	mVp-p	100Hz to 1MHz
Data Rate			1.25		Gbps	TX Rate/RX Rate
Transmission Distance			0.55		KM	
Coupled Fiber		multi mode fiber				50/125um SMF

III. Specification of Transmitter

Parameter	Symbol	Min.	Typ.	Max.	Unit	Note
Average Output Power	POUT	-9.5		-3	dBm	
Extinction Ratio	ER	9			dB	
Center Wavelength	λ C	840	850	860	nm	

Spectrum Width (RMS)	σ			0.85	nm	VCSEL Laser (TX:850nm)
Transmitter OFF Output Power	POff			-45	dBm	
Differential Line Input Impedance	RIN	90	100	110	Ohm	
Total Jitter (Peak-Peak)	tJ			128	ps	Note (1)
Output Eye Mask	Compliant with IEEE802.3Z (class 1 laser safety)					Note (2)

Note (1): Measure at 2⁷-1 NRZ PRBS pattern.

Note (2): Transmitter eye mask definition.

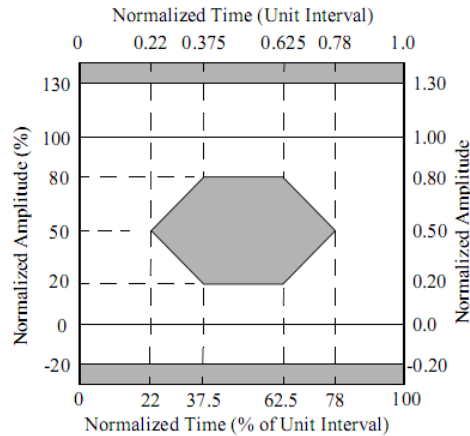

IV. Specification of Receiver

Parameter	Symbol	Min.	Typ.	Max.	Unit	Note
Input Optical Wavelength	λ_{IN}	830	850	870	nm	
Receiver Sensitivity	PIN			-18	dBm	Note (1)
Input Saturation Power (Overload)	PSAT	-3			dBm	
Los Of Signal Assert	PA	-37			dBm	
Los Of Signal De-assert	PD			-19	dBm	Note (2)
LOS Hysteresis	PA-PD	0.5		7	dB	

Note (1): Measured with Light source 850nm, ER=10dB; BER =10^{-10} @PRBS=2⁷-1 NRZ

Note (2): When LOS de-asserted, the RX data+/- output is High-level (fixed).

V. Electrical Interface Characteristics

Parameter	Symbol	Min.	Typ.	Max.	Unit	Note
Transmitter						
Total Supply Current	ICC			A	mA	Note (1)
Transmitter Disable Input-High	VDISH	2		V _{CC} +0.3	V	
Transmitter Disable Input-Low	VDISL	0		0.8	V	
Transmitter Fault Input-High	VDISL	2		V _{CC} +0.3	V	
Transmitter Fault Input-Low	VTxFH	0		0.8	V	
Receiver						
Total Supply Current	ICC			B	mA	Note (1)

LOSS Output Voltage-High	VLOSH	2		Vcc+0.3	V	LVTTTL
LOSS Output Voltage-Low	VLOSL	0		0.8	V	

Note(1): A (TX)+ B (RX) = 280mA (Not include termination circuit)

VI. Pin Diagram

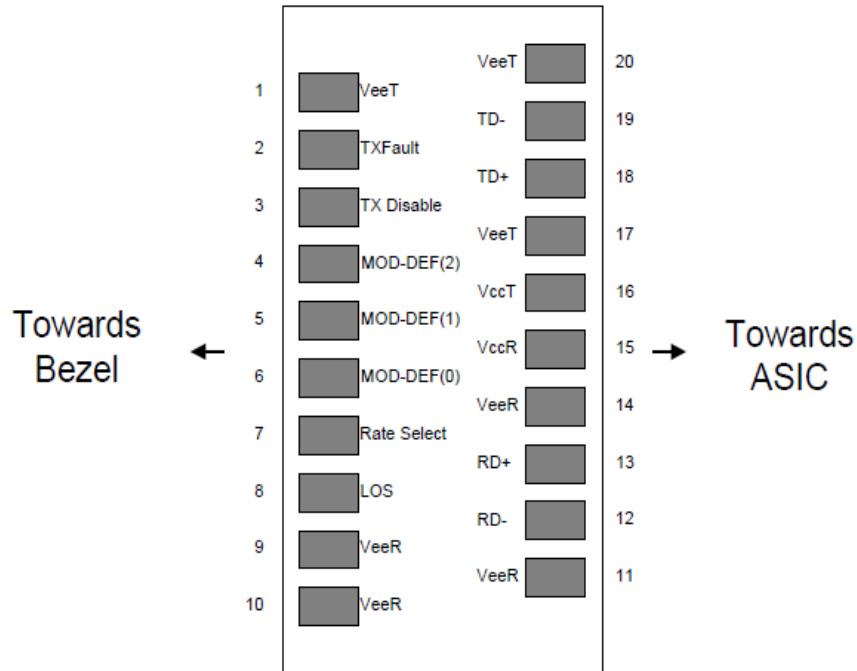

Pinout of Connector Block on Host Board

VII. Pin Descriptions

Pin	Symbol	Name/Description	Ref.
1	VEET	Transmitter Ground (Common with Receiver Ground)	1
2	TFAULT	Transmitter Fault.	
3	TDIS	Transmitter Disable. Laser output disabled on high or open.	2
4	MOD_DEF(2)	Module Definition 2. Data line for Serial ID.	3
5	MOD_DEF(1)	Module Definition 1. Clock line for Serial ID.	3
6	MOD_DEF(0)	Module Definition 0. Grounded within the module.	3
7	Rate Select	No connection required	4
8	LOS	Loss of Signal indication. Logic 0 indicates normal operation.	5
9	VEER	Receiver Ground (Common with Transmitter Ground)	1
10	VEER	Receiver Ground (Common with Transmitter Ground)	1
11	VEER	Receiver Ground (Common with Transmitter Ground)	1
12	RD-	Receiver Inverted DATA out. AC Coupled	
13	RD+	Receiver Non-inverted DATA out. AC Coupled	

14	VEER	Receiver Ground (Common with Transmitter Ground)	1
15	VCCR	Receiver Power Supply	
16	VCCT	Transmitter Power Supply	
17	VEET	Transmitter Ground (Common with Receiver Ground)	1
18	TD+	Transmitter Non-Inverted DATA in. AC Coupled.	
19	TD-	Transmitter Inverted DATA in. AC Coupled.	
20	VEET	Transmitter Ground (Common with Receiver Ground)	1

Notes:

1. Circuit ground is internally isolated from chassis ground.
2. Laser output disabled on TDIS >2.0V or open, enabled on TDIS <0.8V.
3. Should be pulled up with 4.7k - 10kohms on host board to a voltage between 2.0V and 3.6V.
MOD_DEF(0) pulls line low to indicate module is plugged in.
4. This is an optional input used to control the receiver bandwidth for compatibility with multiple data rates (most likely Fiber Channel 1x and 2x Rates). If implemented, the input will be internally pulled down with > 30kΩ resistor. The input states are:
 Low (0 – 0.8V): Reduced Bandwidth
 (>0.8V, < 2.0V): Undefined
 High (2.0 – 3.465V): Full Bandwidth
 Open: Reduced Bandwidth
5. LOS is open collector output. Should be pulled up with 4.7k - 10kohms on host board to a voltage between 2.0V and 3.6V. Logic 0 indicates normal operation; logic 1 indicates loss of signal.

VIII. Recommend Circuit Schematic

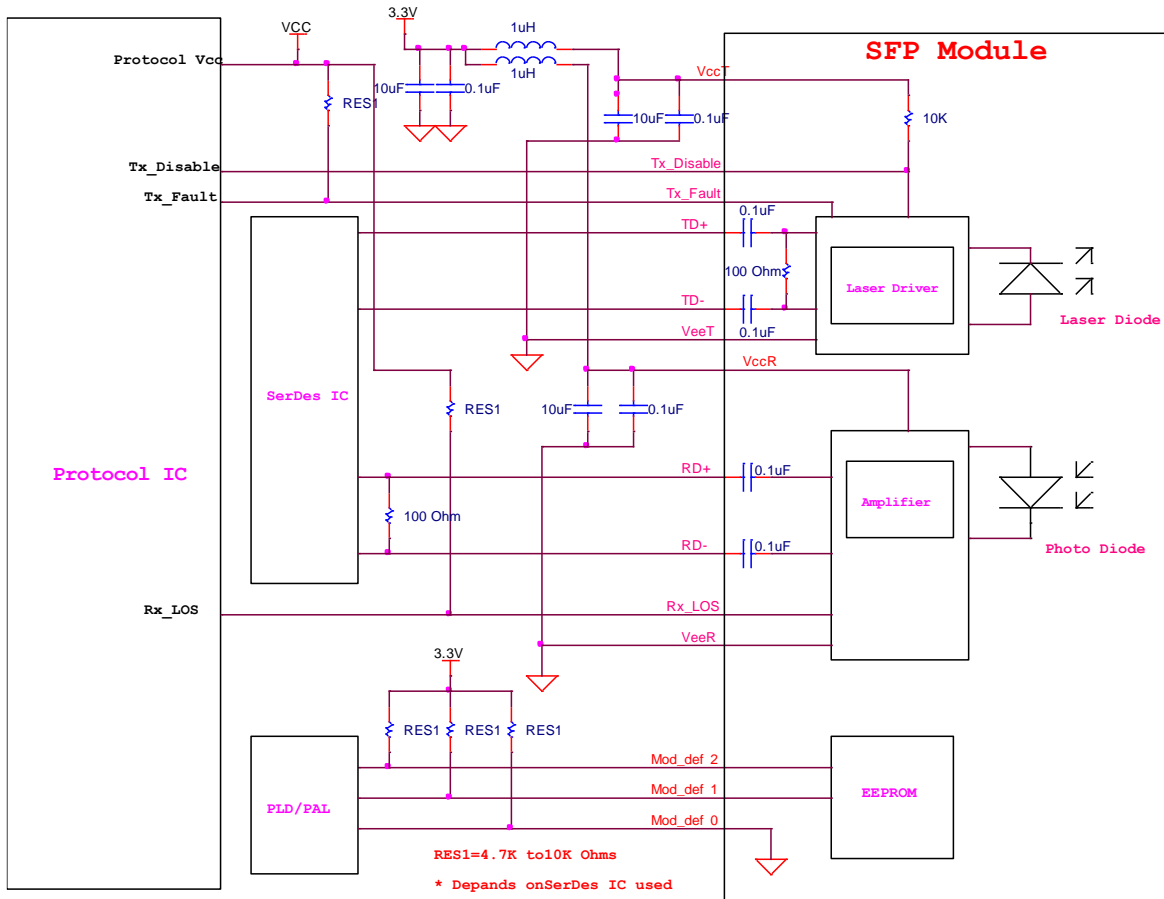

IX. Digital Diagnostic Monitoring Information

Parameter	unit	Actual Value	Note
Transceiver Temperature	°C	+/-3	
Power Supply Voltage	%	+/-3	
Tx Bias Current	%	+/-10	
Tx Optical Power	dBm	+/-3	
Rx Optical Power	dBm	+/-3	

X. Mechanical Specifications(Unit: mm)

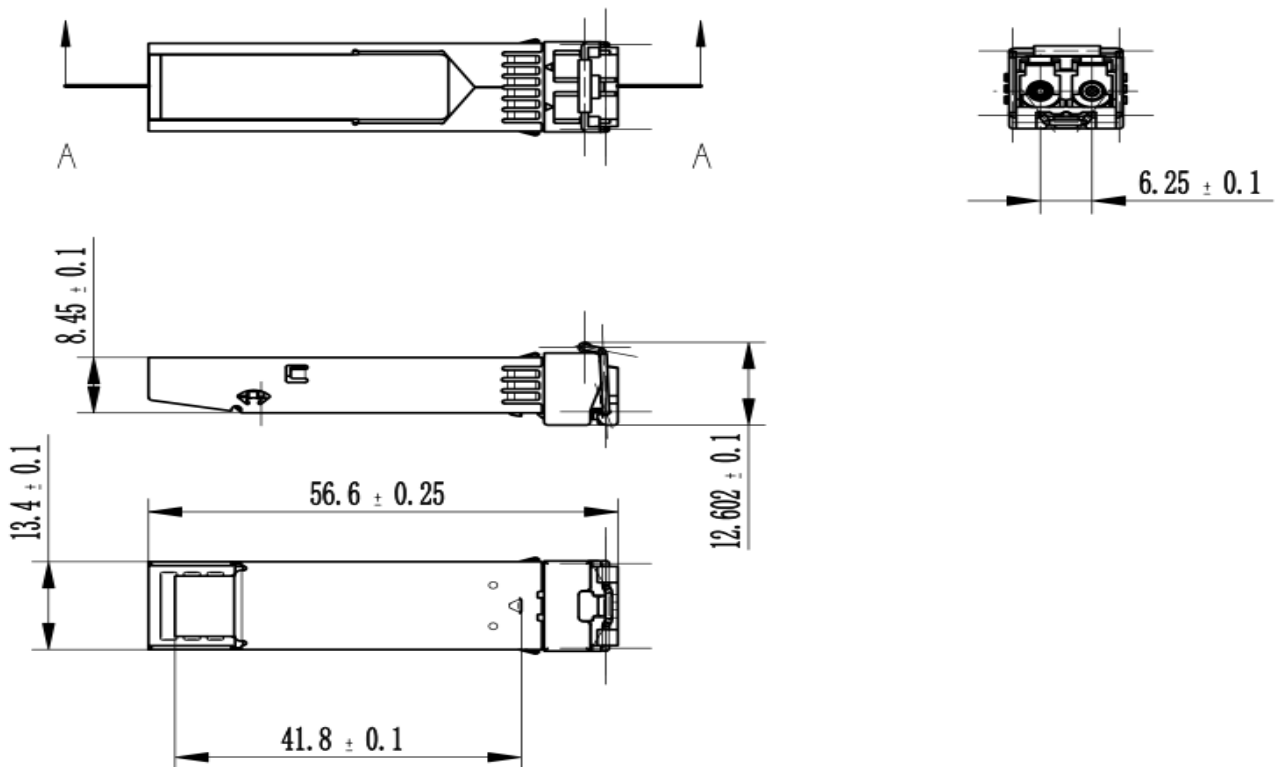

Revision History

Version No.	Date	Description
1.0	June 24, 2020	Preliminary datasheet