

LXP-H31-40D(I)

10Gb/s SFP+ Single-mode 40km DDM Transceiver

PRODUCT FEATURES

- Support data rate up to 11.3Gb/s
- Hot-Pluggable SFP Footprint and Single LC Connector
- Up to 40km reach for G.652 SMF
- 1310nm DFB laser and PIN receiver
- Temperature Range:
 - Commercial: 0°C ~+70°C
 - Industrial: -40°C ~+85°C
- Compliant with SFP-8431
- Compliant with SFP-8432
- Compliant with SFP-8472

APPLICATIONS

- 10G Ethernet
- OTU2/2e
- Other Optical Links

Ordering information

Package	Product part NO.	Data Rate(Gbps)	Media	Transmission Distance(km)	Temperature Range (°C)		Power Dissipation (W)
SFP+	LXP-H31-40D	10.3125	SMF	40	0~70	Commercial	<1.0
SFP+	LXP-H31-40DI	10.3125	SMF	40	-40-85	Industrial	<1.0

I. Absolute Maximum Ratings

Parameter	Symbol	Min.	Max.	Unit
Storage Temperature	TS	-40	+85	°C
Maximum Supply Voltage	VCC	-0.5	3.6	V
Operating Relative Humidity	RH		95	%

II. Recommended Operating Conditions

Parameter	Symbol	Min.	Typ.	Max.	Unit	Note	
Case Operating Temperature	Top	0	-	70	°C	Commercial	
		-40		85		Industrial	
Power Supply Voltage	VCC	3.13	3.3	3.47	V		
Data Rate	BR	1.25	10.3125	11.3	Gbps		
Transmission Distance	TD			40	km		
Coupled fiber	Single mode fiber						9/125um SMF

III. Electrical Characteristics (TOP = Tc, Vcc = 3.135 to 3.465 Volts)

Parameter	Symbol	Min.	Typical	Max.	Unit	Note
Supply Voltage	Vcc	3.135		3.465	V	
Supply Current	Icc			300	mA	
Power Consumption	P			1.0	W	
Transmitter Section						
CML Inputs(Differential)	Vin	190		700	mVpp	1
Input Impedance(Differential)	Zin	90	100	105	ohm	
TX_DIS Disable		2		Vcc+0.3	V	
TX_DIS Enable		0		0.8	V	

TX_FAULT Fault		2		V _{cc} +0.3	V	
TX_FAULT Normal		0		0.5	V	
Receiver Section						
CML Outputs (Differential)	V _{out}	350		700	mV _{pp}	1
Output Impedance (Differential)	Z _{out}	90	100	105	Ohm	
RX_LOS LOS		2		V _{cc} +0.3	V	2
RX_LOS Normal		0		0.8	V	2
MOD_DEF (0:2) VoH		2.5			V	With Serial ID
MOD_DEF (0:2) VoL		0		0.5	V	With Serial ID

Note:

1. CML logic, internally AC coupled.
2. Loss Of Signal is LVTTTL. Logic 0 indicates normal operation; logic 1 indicates no signal detected.

IV. Optical Characteristics

Parameter	Symbol	Min.	Typ.	Max.	Unit	NOTE
Data Rate		1.25	10.3125	11.3	Gbps	
Transmitter						
Center Wavelength	λ_c	1260	1310	1355	nm	
Spectral Width (-20dB)	$\Delta\lambda$			1	nm	
Side Mode Suppression Ratio	SMSR	30			dB	
Average Output Power	P _{out}	-1		5	dBm	1
Extinction Ratio	ER	4			dB	
Average Power of OFF Transmitter	P _{off}			-30	dBm	
Relative Intensity Noise	RIN			-128	dB/Hz	2
Receiver						
Wavelength Range	λ_c	1260		1620	nm	
Receiver Sensitivity	P _{min}			-16	dBm	3
Receiver Overload	P _{max}	0.5			dBm	
LOS De-Assert	LOSD			-16	dBm	
LOS Assert	LOSA	-30			dBm	
LOS-Hysteresis	Phys	0.5		5	dB	

Notes:

1. Output is coupled into a 9/125um SMF.

2. 12dB reflection.
3. Measured with worst ER, BER less than 1E-12 and PRBS 2^31-1 at 10.3125Gbps.

V. Digital Diagnostic Functions

Parameter	Range	Unit	Accuracy	Calibration
Commercial Temperature	0 to +70	°C	±3°C	Internal / External
Industrial Temperature	-30 to +85	°C	±3°C	Internal / External
Voltage	3.0 to 3.6	V	±3%	Internal / External
Bias Current	10 to 100	mA	±10%	Internal / External
TX Power	-1 to +5	dBm	±3dB	Internal / External
RX Power	-15 to +0.5	dBm	±3dB	Internal / External

Note:

The transceivers provide serial ID memory contents and diagnostic information about the present operating conditions by the 2-wire serial interface (SCL, SDA). The diagnostic information with internal calibration or external calibration all are implemented, including received power monitoring, transmitted power monitoring, bias current monitoring, supply voltage monitoring and temperature monitoring.

VI. Timing Characteristics

Parameter	Symbol	Min.	Typical	Max.	Unit
TX_Disable Assert Time	t_off			100	us
TX_Disable Negate Time	t_on			2	ms
Time to Initialize Include Reset of TX_FAULT	t_int			300	ms
TX_FAULT from Fault to Assertion	t_fault			100	us
TX_Disable Time to Start Reset	t_reset	10			us
Receiver Loss of Signal Assert Time	T _{A,RX_LOS}			100	us
Receiver Loss of Signal Deassert Time	T _{d,RX_LOS}			100	us
Rate-Select Chage Time	t_ratesel			10	us
Serial ID Clock Time	t_serial-clock			100	kHz

VII. SFP Module EEPROM Information and Management

The SFP modules implement the 2-wire serial communication protocol as defined in the SFP -8472. The serial ID information of the SFP modules and Digital Diagnostic Monitor parameters can be accessed through the I2C interface at address A0h and A2h.

The memory is mapped in Table 1.

Detailed ID information (A0h) is listed in Table 2.

And the DDM specification at address A2h.

For more details of the memory map and byte definitions, please refer to the SFF-8472, “Digital Diagnostic Monitoring Interface for Optical Transceivers”. The DDM parameters have been internally calibrated.

Table 1- Digital Diagnostic Memory Map (Specific Data Field Descriptions)

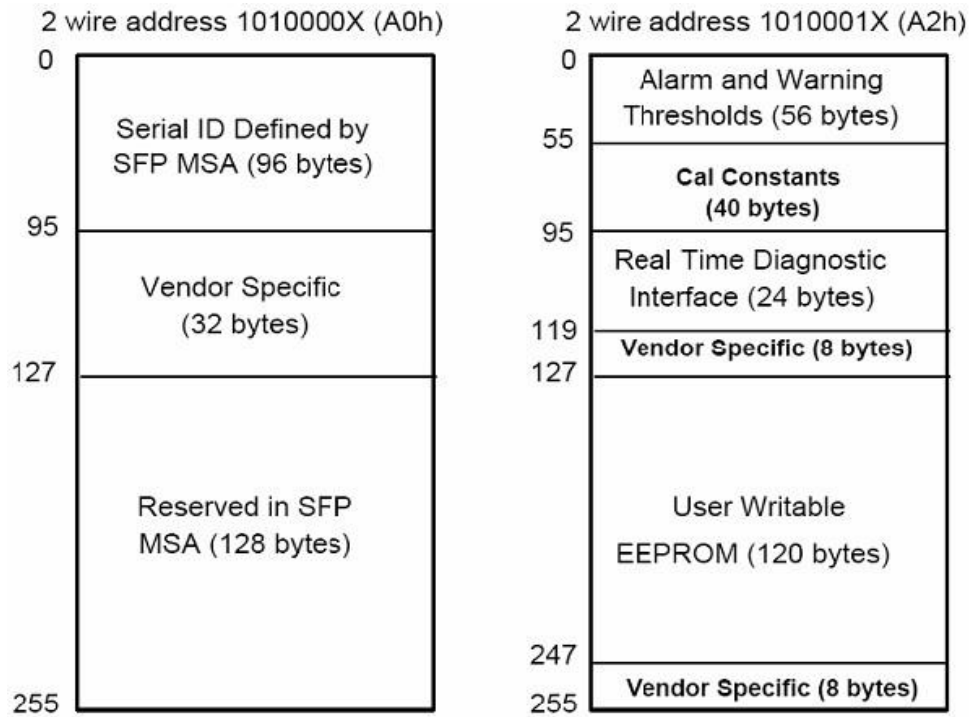

Table 2 - EEPROM Serial ID Memory Contents (A0h)

Data Address	Length (Byte)	Name of Length	Description and Contents
Base ID Fields			
0	1	Identifier	Type of Serial transceiver (03h=SFP)
1	1	Reserved	Extended identifier of type serial transceiver (04h)
2	1	Connector	Code of optical connector type (07=LC)
3-10	8	Transceiver	10G Base-LR
11	1	Encoding	64B/66B
12	1	BR, Nominal	Nominal baud rate, unit of 100Mbps
13-14	2	Reserved	(0000h)
15	1	Length(9um)	Link length supported for 9/125um fiber, units of 100m
16	1	Length(50um)	Link length supported for 50/125um fiber, units of 10m
17	1	Length(62.5um)	Link length supported for 62.5/125um fiber, units of 10m
18	1	Length(Copper)	Link length supported for copper, units of meters
19	1	Reserved	
20-35	16	Vendor Name	SFP vendor name: LIGHTREND
36	1	Reserved	
37-39	3	Vendor OUI	SFP transceiver vendor OUI ID
40-55	16	Vendor PN	Part Number: "LXP-H31-XX" (ASCII)
56-59	4	Vendor rev	Revision level for part number
60-62	3	Reserved	
63	1	CCID	Least significant byte of sum of data in address 0-62
Extended ID Fields			

64-65	2	Option	Indicates which optical SFP signals are implemented (001Ah = LOS, TX_FAULT, TX_DISABLE all supported)
66	1	BR, max	Upper bit rate margin, units of %
67	1	BR, min	Lower bit rate margin, units of %
68-83	16	Vendor SN	Serial number (ASCII)
84-91	8	Date code	LIGHTREND's Manufacturing date code
92-94	3	Reserved	
95	1	CCEX	Check code for the extended ID Fields (addresses 64 to 94)
Vendor Specific ID Fields			
96-127	32	Readable	LIGHTREND specific date, read only
128-255	128	Reserved	Reserved for SFF-8079

Table 3 - Alarm and Warning Thresholds (A2h)

Data Address	Length (Byte)	Name of Length	Description and Contents
Base ID Fields			
00-01	2	Temp High Alarm	MSB at low address
02-03	2	Temp Low Alarm	MSB at low address
04-05	2	Temp High Warning	MSB at low address
06-07	2	Temp Low Warning	MSB at low address
08-09	2	Voltage High Alarm	MSB at low address
10-11	2	Voltage Low Alarm	MSB at low address
12-13	2	Voltage High Warning	MSB at low address
14-15	2	Voltage Low Warning	MSB at low address
16-17	2	Bias High Alarm	MSB at low address
18-19	2	Bias Low Alarm	MSB at low address
20-21	2	Bias High Warning	MSB at low address
22-23	2	Bias Low Warning	MSB at low address
24-25	2	TX Power High Alarm	MSB at low address
26-27	2	TX Power Low Alarm	MSB at low address
28-29	2	TX Power High Warning	MSB at low address
30-31	2	TX Power Low Warning	MSB at low address
32-33	2	RX Power High Alarm	MSB at low address

34-35	2	RX Power Low Alarm	MSB at low address
36-37	2	RX Power High Warning	MSB at low address
38-39	2	RX Power Low Warning	MSB at low address
40-41	2	Optional Laser Temp High Alarm	MSB at low address
42-43	2	Optional Laser Temp Low Alarm	MSB at low address
44-45	2	Optional Laser Temp High Warning	MSB at low address
46-47	2	Optional Laser Temp Low Warning	MSB at low address
48-49	2	Optional TEC Current High Alarm	MSB at low address
50-51	2	Optional TEC Current Low Alarm	MSB at low address
52-53	2	Optional TEC Current High Warning	MSB at low address
54-55	3	Optional TEC Current Low Warning	MSB at low address
Calibration Constants for External Calibration Option			
56-91	36	Calibration Constants for External Calibration Option	Refer to the SFP 8472 Rev12.4
92-94	3	Reserved	
95	1	Checksum	Byte 95 contains the low order 8 bits of the sum of bytes 0-94
Real Time Diagnostic and Control Registers			
96-110	15	A/D Values and Status Bits	Refer to the SFP 8472 Rev12.4
111	1	Reserved	Reserved (was assigned to SFF-8079).
Alarm and Warning Flag Bits			
112-117	6	Optional Alarm and Warning Flag Bits	Refer to the SFP 8472 Rev12.4
Extended Module Control/Status Bytes			

118-119	2	Extended Module Control/Status Bytes	Refer to the SFP 8472 Rev12.4
Optional Page Select Byte			
120-126	7	Vendor Specific	Vendor specific memory addresses
127	1	Optional Page Select	Defines the page number for subsequent reads and writes to locations A2h
User Accessible EEPROM Locations			
128-247	120	User EEPROM	User writable EEPROM
Vendor Specific Control Function Locations			
248-255	8	Vendor Specific	Vendor specific control functions

VIII. Pin Diagram

Diagram of Host Board Connector Block Pin Numbers and Name

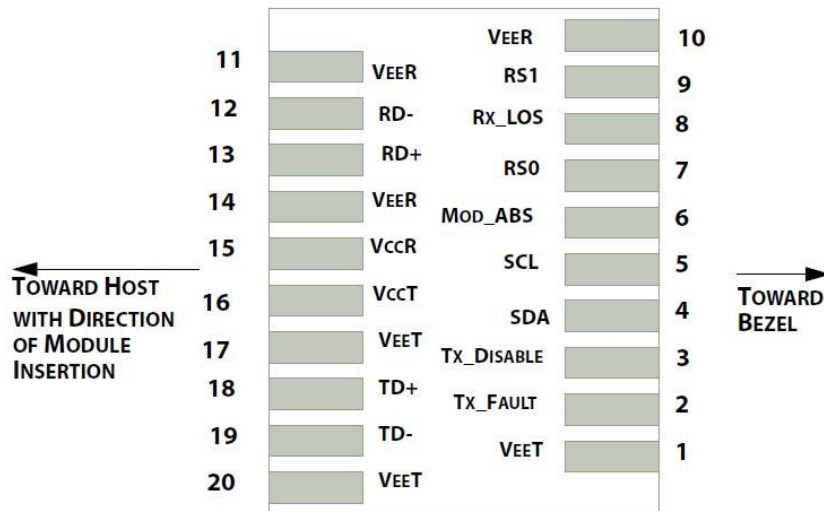

IX. Pin Descriptions

PIN #	Name	Function	Notes
1	VeeT	Module transmitter ground	1
2	Tx Fault	Module transmitter fault	2
3	Tx Disable	Transmitter Disable; Turns off transmitter laser output	3
4	SDL	2 wire serial interface data input/output (SDA)	4
5	SCL	2 wire serial interface clock input (SCL)	4
6	MOD-ABS	Module Absent, connect to VeeR or VeeT in the module	4
7	RS0	Rate select0, optionally control SFP+ receiver. When high, input data	5

		rate >4.5Gb/ s; when low, input data rate <=4.5Gb/s	
8	LOS	Receiver Loss of Signal Indication	6
9	RS1	Rate select0, optionally control SFP+ transmitter. When high, input data rate >4.5Gb/s; when low, input data rate <=4.5Gb/s	1
10	VeeR	Module receiver ground	1
11	VeeR	Module receiver ground	1
12	RD-	Receiver inverted data out put	
13	RD+	Receiver non-inverted data out put	
14	VeeR	Module receiver ground	1
15	VccR	Module receiver 3.3V supply	
16	VccT	Module transmitter 3.3V supply	
17	VeeT	Module transmitter ground	1
18	TD+	Transmitter inverted data out put	
19	TD-	Transmitter non-inverted data out put	
20	VeeT	Module transmitter ground	1

Note:

1. Circuit ground is internally isolated from chassis ground
2. Tx FAULT is an open collector/drain output, which should be pulled up with a 4.7k – 10k Ohms resistor on the host board if intended for use. Pull up voltage should be between 2.0V to Vcc + 0.3V. A high output indicates a transmitter fault caused by either the TX bias current or the TX output power exceeding the preset alarm thresholds. A low output indicates normal operation. In the low state, the output is pulled to <0.8V.
3. Laser output disabled on Tx DIS >2.0V or open, enabled on Tx DIS <0.8V.
4. Should be pulled up with 4.7kΩ- 10kΩ host board to a voltage between 2.0V and 3.6V. MOD_ABS pulls line low to indicate module is plugged in.
5. Internally pulled down per SFF-8431 Rev 4.1.
6. LOS is open collector output. It should be pulled up with 4.7kΩ – 10kΩ on host board to a voltage between 2.0V and 3.6V. Logic 0 indicates normal operation; logic 1 indicates loss of signal.

X. Recommend Circuit Schematic

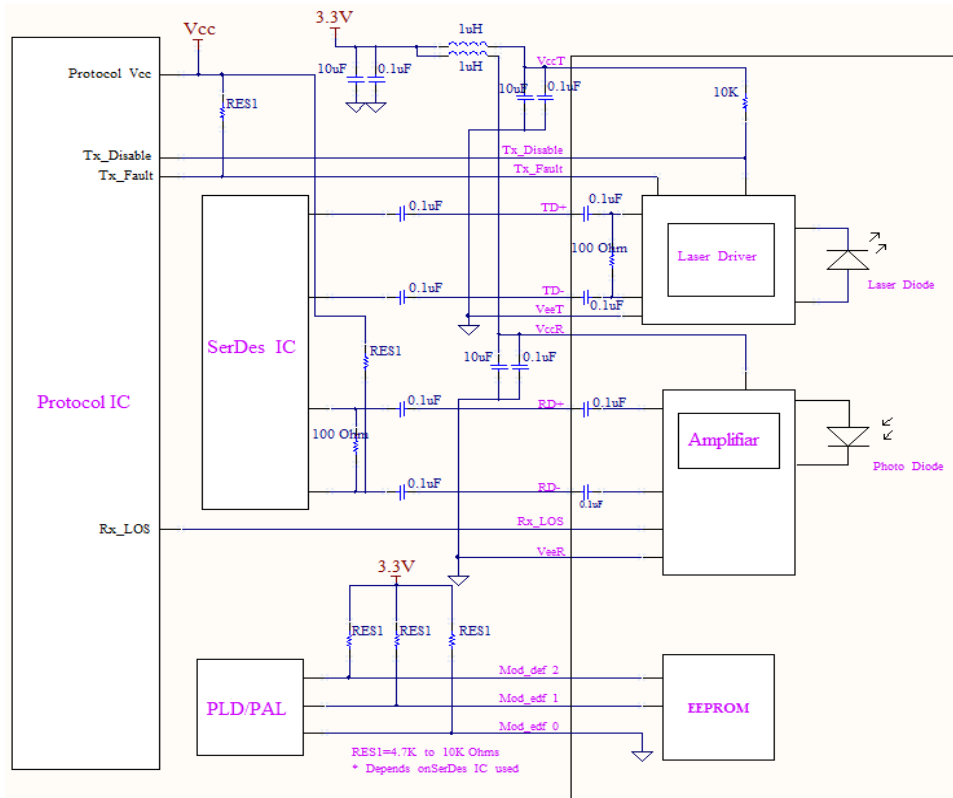

XI. Mechanical Specifications(Unit: mm)

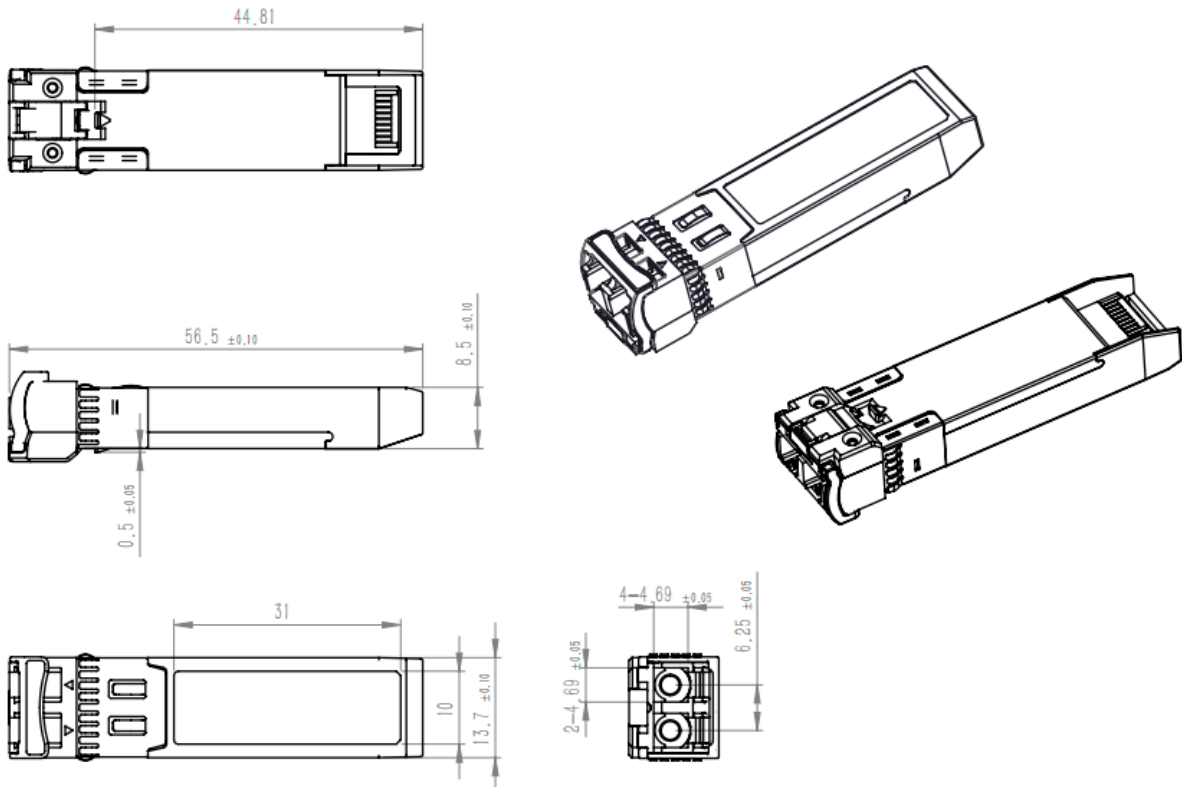

Revision History

Version No.	Date	Description
1.0	June 24, 2020	Preliminary datasheet
1.1	Aug 09, 2022	reformatting
1.2	June 27, 2023	Updated industrial power consumption 1.0W

Contact:

Add: Building 7, Mobile Terminal Industrial Park, East Lake Comprehensive Bonded Zone, 777 Optics Valley 3 Road, East Lake New Technology Development Zone, Wuhan, China

Tel: (+86) 86-27-88870005

Postal: 430205

E-mail: sales@lightrend.com

<http://www.lightrend.com>